

DESCRIPTION

The EV5410EQ-00A is a MP5410 evaluation board that is configured to provide a regulated 10V output from dual-cell NiCd/NiMH or single-cell Li+ battery for low-power bias supply application.

The MP5410 can start up from an input voltage as low as 1.8V. It uses a current limited variable frequency control algorithm to optimize efficiency and minimize external component size and cost. The internal low resistance N-MOS and schottky diode can reduces external parts to save critical board space. With four single-pole/double-throw (SPDT) switches, the system can control four channels bias supply by external logic signals.

In addition, the MP5410 can disconnect all loads from input power supply when the chip is disabled.

ELECTRICAL SPECIFICATIONS

Parameter	Symbol	Value	Units
Input Voltage	V_{IN}	2.0~5.5	V
Output Voltage	V_{OUT}	10	V
Output Current	I_{OUT}	2	mA

FEATURES

- 1.8V Low Voltage Start-Up
- 2.0V to 5.5V Input Range
- Output Disconnection
- Integrated Power MOS & Schottky Diode
- Variable Frequency Control
- $1\mu A$ Shutdown Current
- Current Mode Control with Internal Compensation
- More than 80% Efficiency at Light Load Conditions
- Tiny External Components
- Inrush Current Limiting & Internal Soft-Start
- Input UVLO
- Over Temperature Protection
- Fully Assembled and Tested

APPLICATION EXAMPLES

- Dual-cell and Three-cell NiCd/NiMH or Single-cell Li Battery Consumer Products
- 3D Glass Driver
- Small LCD Displays Bias Supply
- Digital Still and Video Cameras
- Handheld Computers and PDAs
- Cell Phones

For MPS green status, please visit MPS website under Quality Assurance. "MPS" and "The Future of Analog IC Technology" are Registered Trademarks of Monolithic Power Systems, Inc.

EV5410EQ-00A EVALUATION BOARD



(L x W x H) 2.0" x 1.8" x 0.1"
(5.0cm x 4.6cm x 0.35cm)

Board Number	MPS IC Number
EV5410EQ-00A	MP5410EQ

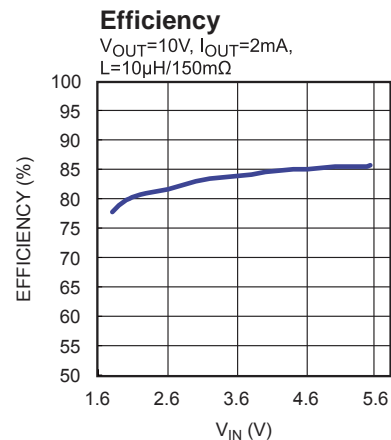

EVALUATION BOARD SCHEMATIC

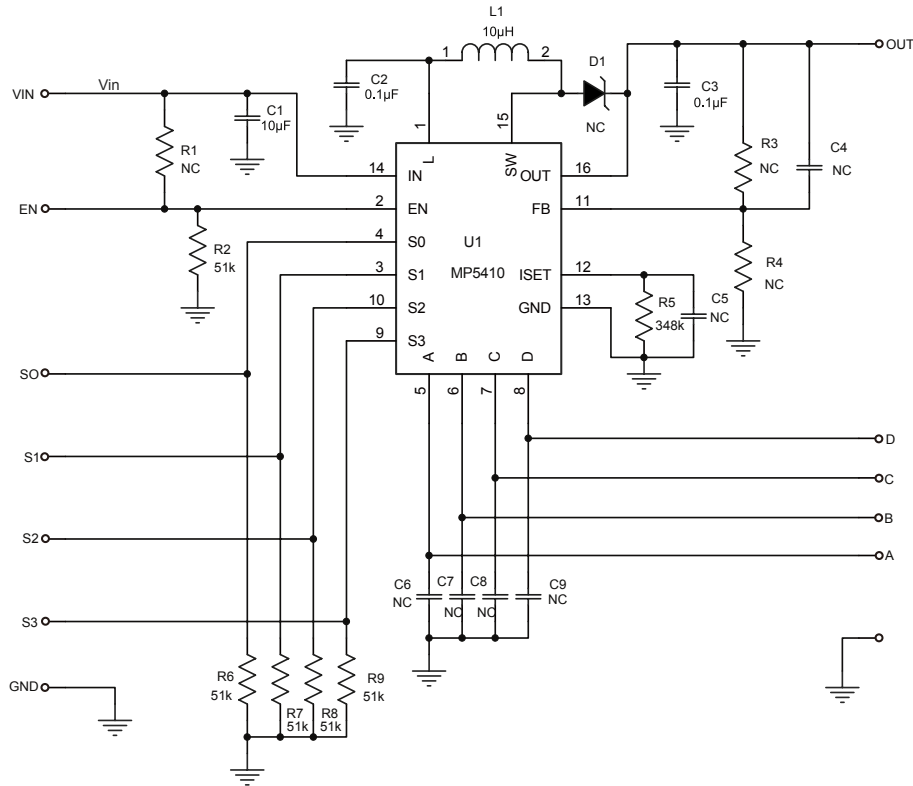

EV5410EQ-00A BILL OF MATERIALS

Qty	Ref	Value	Description	Package	Manufacturer	Part No.
1	C1	10µF	Ceramic Capacitor, 16V, X7R	0805	muRata	GRM21BR61C106KE15
1	C2	0.1µF	Ceramic Capacitor, 16V, X7R	0603	muRata	GRM188R71C104KA01D
1	C3	0.1µF	Ceramic Capacitor, 16V, X7R	0805	muRata	GRM219R71C104KA01D
6	C4, C5, C6, C7, C8, C9	NC				
1	D1	NC				
1	L1	10µH	Inductor 0.903A	SMD	Cooper	SD20-100-R
3	R1, R3, R4	NC				
5	R2, R6, R7, R8, R9	51kΩ	Film Resistor, 5%	0603	Any	
1	R5	348kΩ	Film Resistor, 1%	0603	Any	
1	U1	MP5410	Boost Converter w/ SPDT	QFN16(3x3)	MPS	MP5410EQ-LF-Z

PRINTED CIRCUIT BOARD LAYOUT

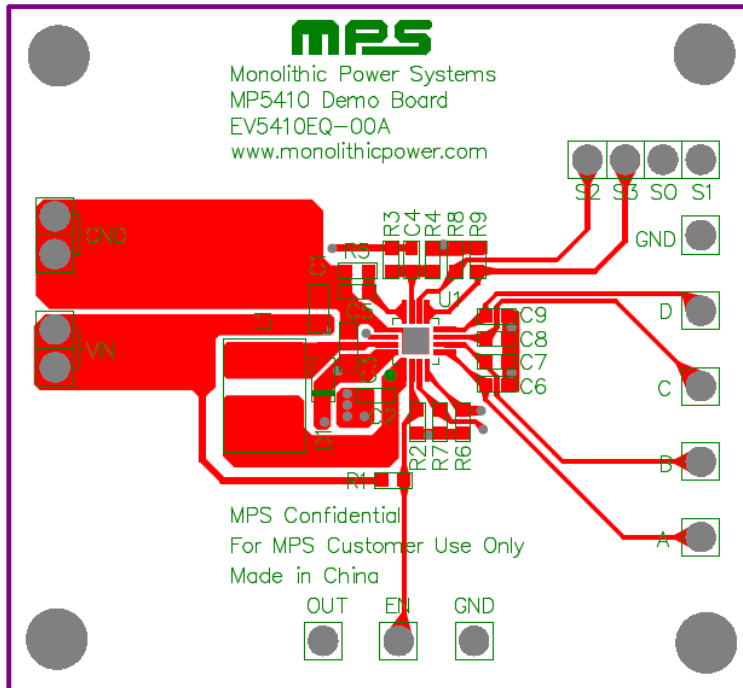

Figure 1—Top Layer

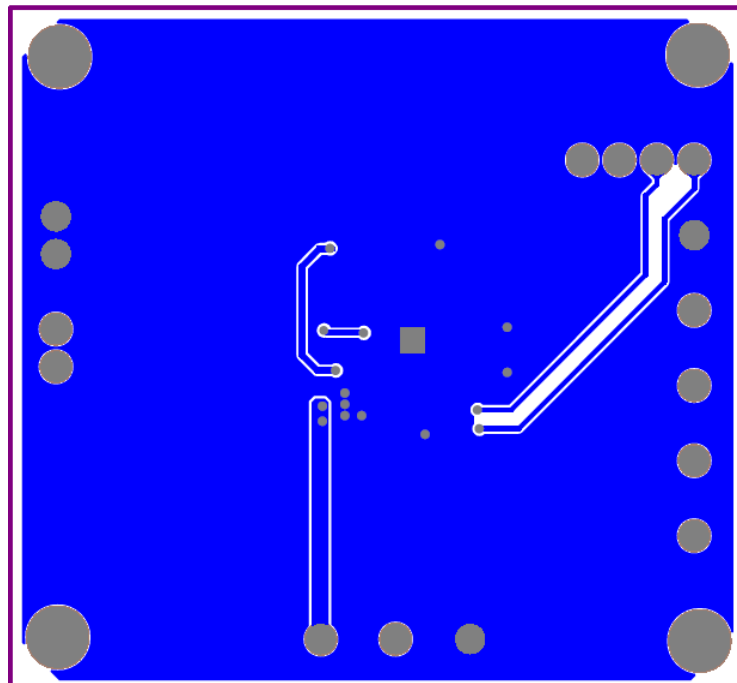

Figure 2—Bottom Layer

QUICK START GUIDE

The output voltage of this board is set to 10V. The board layout accommodates most commonly used inductors and output capacitor.

1. Connect the positive and negative terminals of load to the A/B/C/D and GND pins on the demo board, respectively.
2. Connect the positive and negative terminals of the power supply (2.0V~5.5V) to the VIN and GND pins on the demo board, respectively. Turn the power supply on.
3. To enable the MP5410, apply a voltage V_{EN} ($V_{EN} \geq 1.4V$) to the EN pin. To disable the MP5410, connect the EN pin to GND.
4. To enable the channel A/B/C/D, apply a voltage V_{SX} ($V_{SX} \geq 1.4V$) to the SX pin. To disable the channel A/B/C/D, connect the SX pin to GND. (X=0, 1, 2, 3)
5. To adjust the output voltage, please add external resistor divider R3 & R4. The output voltage V_{OUT} can be changed by varying R3. Calculate the new value using the formula:

$$R3 = \left(\frac{V_{OUT}}{V_{FB}} - 1 \right) \times R4$$

Where $V_{FB} = 1.23V$.

For example, for $V_{OUT} = 9.6V$ and $R4 = 100k\Omega$

$$R3 = \left(\frac{9.6V}{1.23V} - 1 \right) \times 100k\Omega = 680.5k\Omega$$

Therefore use a 680k Ω standard 1% value

NOTICE: The information in this document is subject to change without notice. Please contact MPS for current specifications. Users should warrant and guarantee that third party Intellectual Property rights are not infringed upon when integrating MPS products into any application. MPS will not assume any legal responsibility for any said applications.