



The Future of Analog IC Technology®

EV5003EQ-00A

Programmable Current 3.3V/1~3A
Electronic Fuse Evaluation Board

DESCRIPTION

The EV5003EQ-00A is the evaluation board for the MP5003EQ, a protection device designed to protect circuitry on the output (V_{out}) from transients on input (V_{in}). It also protects V_{in} from undesired shorts and transients coming from the source.

Besides the input capacitor and output capacitor, EV5003EQ-00A contains a low power resistor to set the current limit (I_{LIMIT}) and an optional small capacitor to program the ramp up rate of output voltage (dv/dt).

The demo board defaults are for a 2.35 V turn on point and a 4.03 V over voltage clamp. The trip current limit is set at 2.5A ,and hold current is set at 1.55A.

ELECTRICAL SPECIFICATIONS

Parameter	Symbol	Value	Units
Input Voltage	V _{IN}	2.35-4.03	V
Output Voltage Clamp	V _{OUT}	4.03	V
Trip Current	I _{TRIP}	2.5	A
Hold Current	I _{HOLD}	1.55	A

FEATURES

- Adjustable Slew Rate for Output Voltage
- 2.5A Trip Current and 1.55A Hold Current
- Integrated Power FET Thermal Protection
- Over Voltage Limit

APPLICATIONS

- Hot Swap
- PC Cards
- Cell Phones
- Laptops

"MPS" and "The Future of Analog IC Technology" are Registered Trademarks of Monolithic Power Systems, Inc.

EV5003EQ-00A EVALUATION BOARD



(L x W x H) 1.97" x 1.89" x 0.12"
(5.0cm x 4.8cm x 0.3cm)

Board Number	MPS IC Number
EV5003EQ-00A	MP5003EQ

Trip and Hold Current vs. R_{LIMIT}

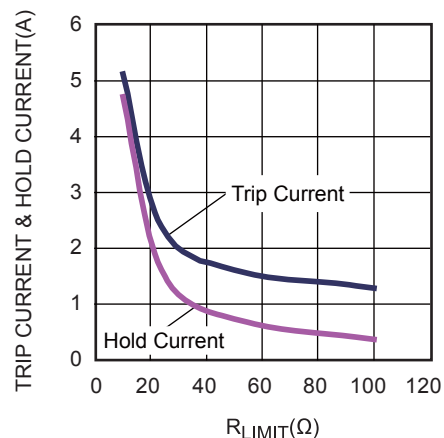

EVALUATION BOARD SCHEMATIC

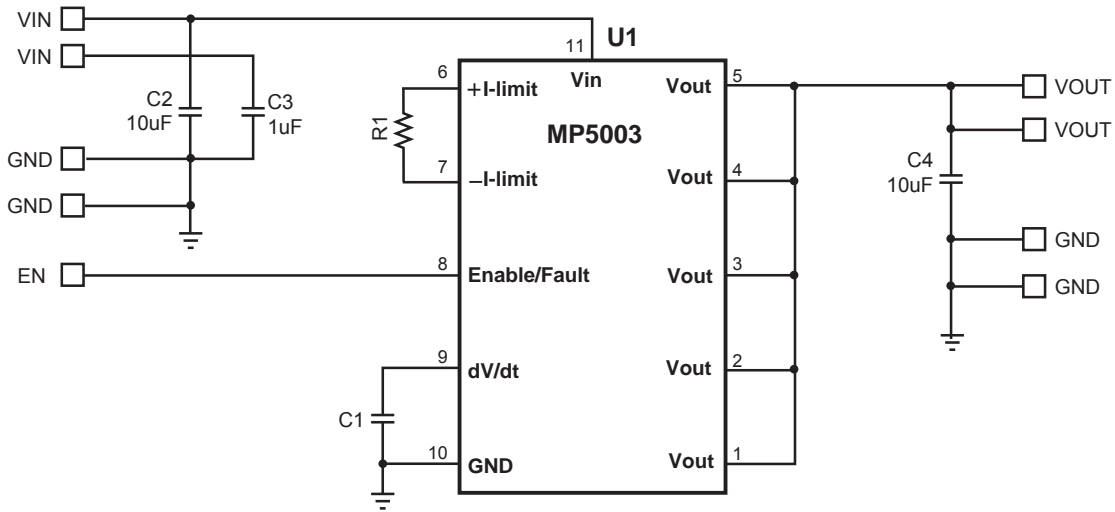

EV5003EQ-00A BILL OF MATERIALS

Qty	Ref	Value	Description	Package	Manufacturer	Manufacturer P/N
1	C1	NS				
2	C2,C4	10uF	Ceramic Cap., X5R, 25V	1206	TDK	C3216X5R1E106K
1	C3	1uF	Ceramic Cap., X7R, 16V	0603	Murata	GRM188R71C105KA12D
1	R1	24Ω	Film Res., 1%	0603	Yageo	RC0603FR-0724RL
1	U1		Electronic Fuse	QFN-10	MPS	MP5003EQ

PRINTED CIRCUIT BOARD LAYOUT

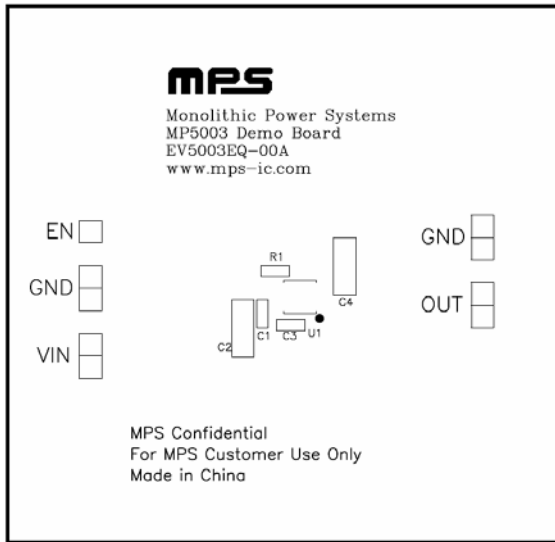

Figure 1—Top Silk Layer

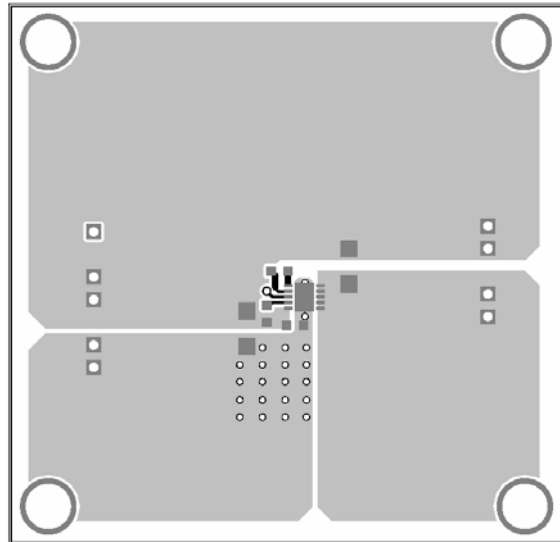

Figure 2—Top Layer

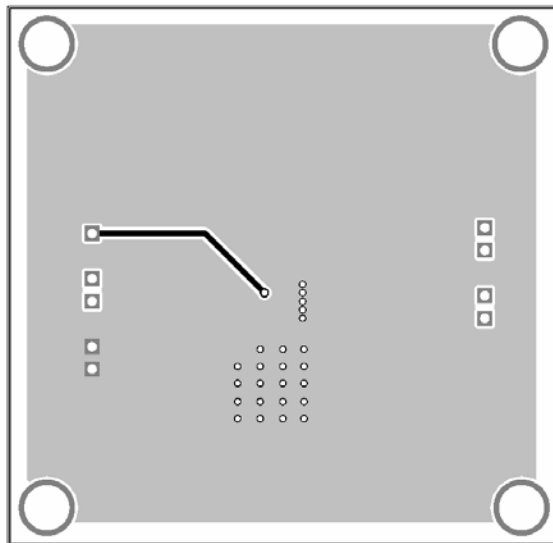

Figure 3—Bottom Layer

QUICK START GUIDE

1. Connect the positive terminal of the load to VOUT pins, and the negative terminal of the load to GND pins.
2. Preset the power supply output to 2.35V-4.03V and turn off the power supply.
3. Connect the positive terminal of the power supply output to the VIN pin and the negative terminal of the power supply output to the GND pin.
4. Turn the power supply on. The MP5003EQ will automatically startup.
5. To use the Enable function, apply a digital input to EN pin. Drive EN higher than 2.5V to turn on the regulator, drive EN less than 0.5V to turn it off.
6. When the die temperature reaches the thermal shutdown temperature, the output will be turned off and the enable/fault pin will be driven to the low level, when the die cools down below the thermal hysteresis level, the MP5003 will restart in the start up mode and the fault line will be pulled high.
7. The trip current of this board is set to 2.5A, the hold current is set to 1.55A, rated output current should be less than hold current. And the output voltage rising time is set to 1.4ms. Both of the two parameters can be programmed. For detailed application, please refer to the MP5003EQ datasheet.

NOTICE: The information in this document is subject to change without notice. Users should warrant and guarantee that third party Intellectual Property rights are not infringed upon when integrating MPS products into any application. MPS will not assume any legal responsibility for any said applications.