

### DESCRIPTION

The MP4690 is a MOSFET based smart bypass for LED open protection, which provides a current bypass in the case of a single LED fails and becomes an open circuit. When the LED heals itself or is replaced, the MP4690 automatically resets. This device features very low voltage drop so that the conduction loss is very small during the protection. It achieves excellent thermal performance and energy efficiency.

LED lighting requires high reliability, especially in applications, such as automobiles, aircrafts, and streetlights. The MP4690 is used in parallel with each LED so that when one LED fails, other LEDs in the same string can still function normally.

### ELECTRICAL SPECIFICATIONS

Parameter	Symbol	Value	Units
Output Current	$I_{LED}$	350 (500 Max)	mA
LED Forward Voltage Drop	$V_{LED}$	3.5	V

### FEATURES

- Simple Two Terminal Device
- Automatic Reset if the LED Heals itself or is Replaced
- 0.22Ω Typical On-state Resistance
- Less than 1μA Off-state Current

### APPLICATIONS

- LEDs where Preventive Maintenance is not Practical
- LED Headlights
- LEDs with high Reliability Requirements
- Crowbar Protection for Open Circuit Conditions
- Over-voltage Protection for Sensitive Circuits

For MPS green status, please visit MPS website under Quality Assurance "MPS" and "The Future of Analog IC Technology" are Registered Trademarks of Monolithic Power Systems, Inc.

### EV4690GSD-00A EVALUATION BOARD



## EVALUATION BOARD SCHEMATIC

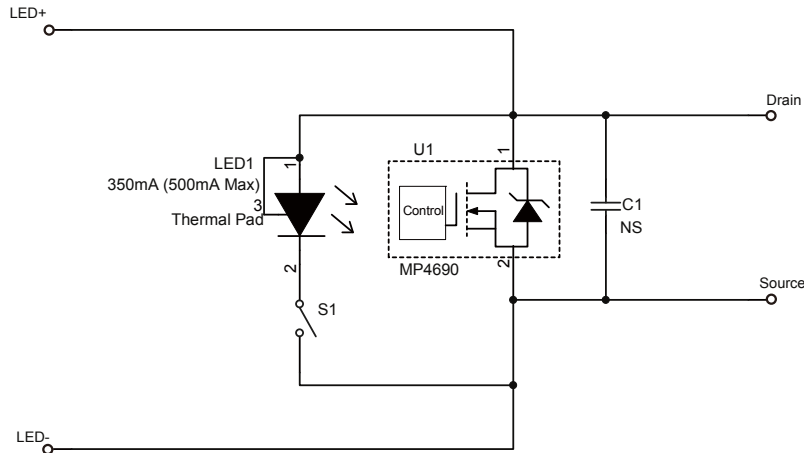

## TYPICAL APPLICATION SCHEMATIC

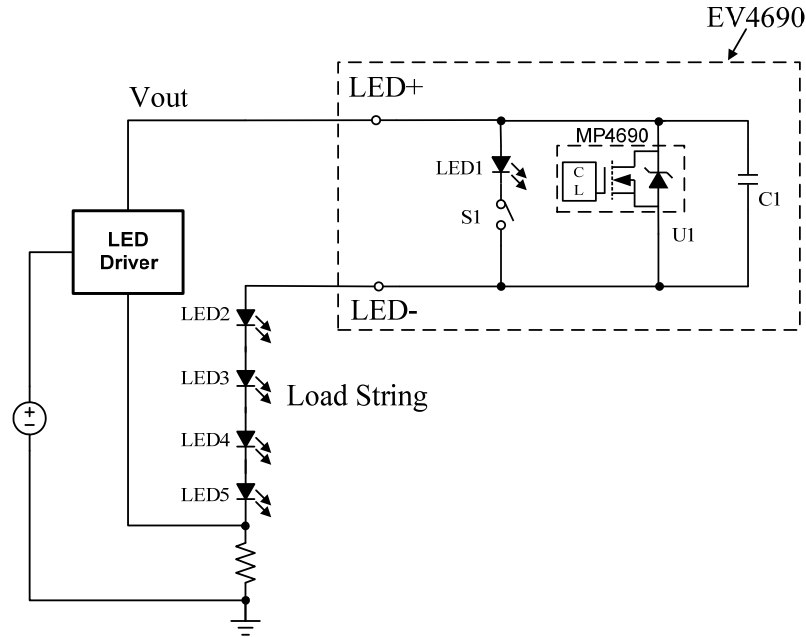
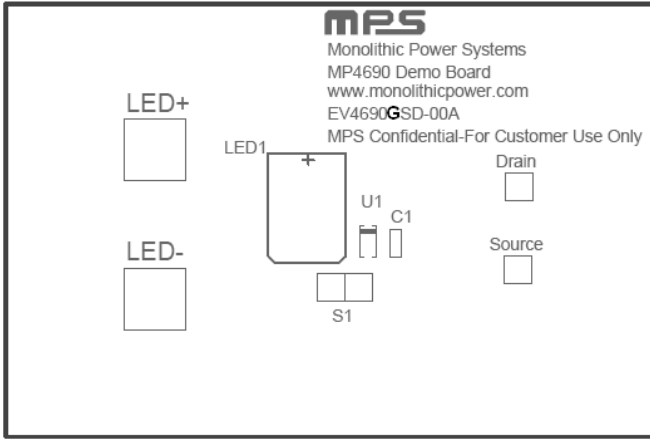

Figure 1. EV4690 Typical Application Circuit

## EVALUATION BOARD SCHEMATIC BILL OF MATERIALS

Qty	Ref Des	Value	Description	Package	Manufacturer	Manufacturer P/N
0	C1		Not Stuffed			
1	LED1	350mA	WLED, 3.5V@350mA	SMD	CREE	XRCWHT-L1-0000-00701
1	S1		Jumper		Any	
1	U1		Smart bypass for LED open protection	SOD123	MPS	MP4690GSD

**PRINTED CIRCUIT BOARD LAYOUT**



**Figure 2—Top Silk Layer**

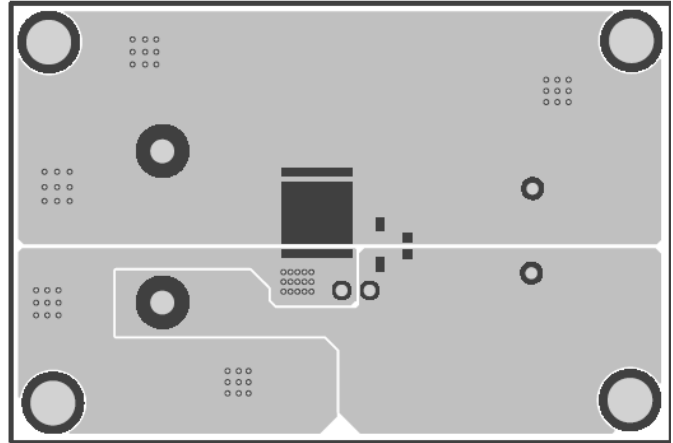

**Figure 3—Top Layer**

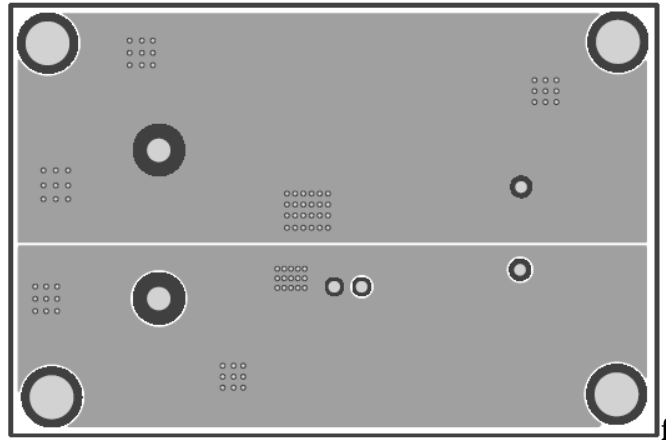

**Figure 4—Bottom Layer**

## QUICK START GUIDE

The EV4690 must be used with LED load string as Figure 1 shows. It acts like a LED lamp which can bypass itself when open circuit happens. The EV4690 can be used by inserting it into any place of the original LED load string.

1. Close the switch S1.
2. Connect the LED+ and LED- terminals of the EV4690 to the Vout of LED driver and anode of LED2, respectively. (Refer to Figure 1)
3. Turn on the LED driver. Check the LED normal operation status.
4. Open the switch S1. Check the open protection function of EV4690.
5. Close the switch S1 to check the auto recovery function when open circuit heals.

**NOTICE:** The information in this document is subject to change without notice. Users should warrant and guarantee that third party Intellectual Property rights are not infringed upon when integrating MPS products into any application. MPS will not assume any legal responsibility for any said applications.