



The Future of Analog IC Technology®

# EV3900DK-00B

## High Efficiency Boost Controller

### DESCRIPTION

The EV3900DK-00B is an evaluation board for the MP3900DK. It is configured to provide a regulated 25V output at up to 2A load current from a 12V input. The output is adjustable by changing feedback resistors on the evaluation board. MOSFET  $R_{ds,on}$  can be directly used for current sense purpose without an external sense resistor.

Although the demo board uses the external 10mΩ to sense the current, it also provides the stuffing option for users who want to use the  $R_{ds,on}$  as the sense element.

### ELECTRICAL SPECIFICATIONS

Parameter	Symbol	Value	Units
Input voltage	$V_{IN}$	10~20	V
Input current	$I_{IN}$	0~6	A
Output voltage	$V_O$	25	V
Output Current	$I_o$	2	A

### FEATURES

- Current Mode Control
- Undervoltage Lockout
- Cycle-by-Cycle Current Limiting
- Lossless Current Sense ( $V_{ISENSE} < 30V$ )
- 10μA Shutdown Current
- 180μA Quiescent Current
- 330KHz Constant Frequency Operation

### APPLICATIONS

- TV CCFL Power Generation
- Telecom Isolated Power
- Brick Modules

"MPS" and "The Future of Analog IC Technology" are Registered Trademarks of Monolithic Power Systems, Inc.

### EV3900DK-00B EVALUATION BOARD



(L x W x H) 1.8" x 1.8" x 0.4"  
4.6cm x 4.6cm x 1.0cm

Board Number	MPS IC Number
EV3900DK-00B	MP3900DK

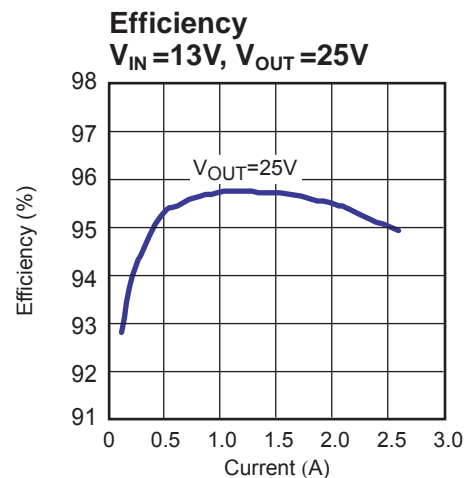

## EVALUATION BOARD SCHEMATIC

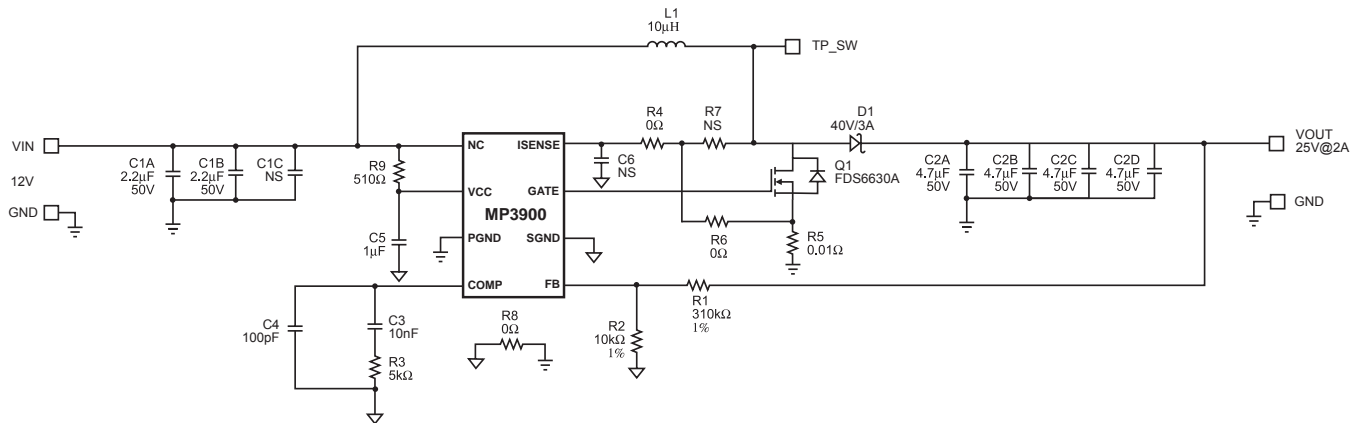

## EV3900DK-00B BILL OF MATERIALS

Qty	Ref	Value	Description	Package	Manufacturer	Part Number
2	C1A, C1B	2.2uF	Ceramic Cap, 50V, X7R	1210	TDK	C3225X7R1H225K
1	C1C, C6	NS				
4	C2A, C2B, C2C, C2D	4.7uF	Ceramic Cap, 50V, X7R		AVX	12105C475KAZ2A
1	C3	10nF	Ceramic Cap, 50V, X7R	0603	TDK	C1068X7R1H103K
1	C4	100pF	Ceramic Cap, 50V, X7R	0603	TDK	C1068X7R1H101K
1	C5	1uF	Ceramic Cap, 16V, X5R	0603	TDK	C1608X5R1C105K
1	R1	301kΩ	Metal Film Res, 1%	0603	Panasonic	ERJ-3EKF3013V
1	R2	10kΩ	Metal Film Res, 1%	0603	Panasonic	ERJ-3EKF1002V
1	R3	5kΩ	Metal Film Res, 5%	0603	Panasonic	ERJ-3EKF4991V
3	R4, R6,R8	0Ω	Metal Film Res, 5%	0603	Panasonic	ERJ-3GEY0R00V
1	R5	0.01Ω	Metal Strip Res, 1%	1210	Dale/Vishay	WSL1206R0100FEA
1	R7	NS				
1	R9	510Ω	Metal Film Res, 5%	0805	Panasonic	ERJ-6GEYJ510V
1	L1	10uH	6A	SMD	Sumida	CDRH127/LDNP-100MC
1	D1		Schottky Diode, 40V, 3A	SMA	On Semiconductor	MBRA340T3
1	Q1		MOSFET 30V, 6.5A	SO-8	Fairchild	FDS6630A
1	U1		Boost controller	MSOP8	MPS	MP3900D

**PRINTED CIRCUIT BOARD LAYOUT**

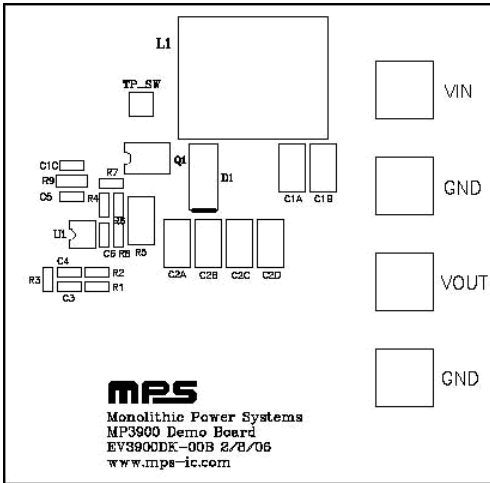

**Figure 1—Top Silk Layer**

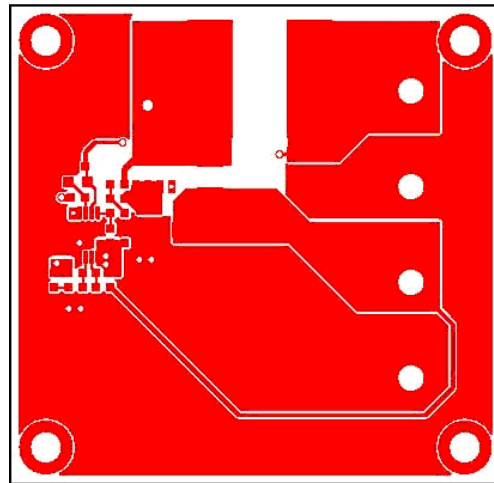

**Figure 2—Top Layer**

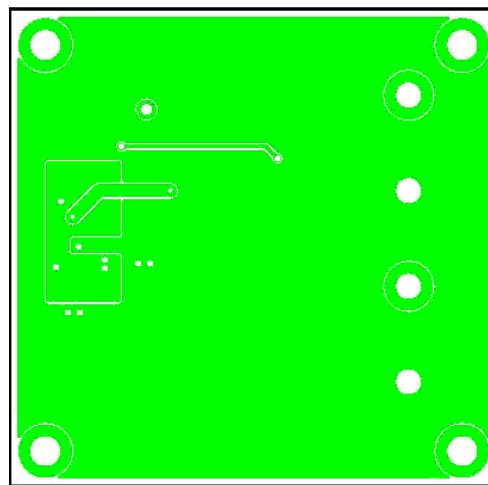

**Figure 3—Bottom Layer**

## QUICK START GUIDE

1. The output voltage of this board is set to 25V. The board layout accommodates most commonly used inductors and output capacitors.
2. Preset Power Supply to  $10V \leq V_{IN} \leq 20V$ .
3. Turn Power Supply off.
4. Connect the power supply terminals to:  
Positive (+): VIN  
Negative (-): GND  
Connect the load to:  
Positive (+): VOUT  
Negative (-): GND  
Load current is up to 2A.
5. Turn on the power supply after making connections.
6. The MP3900 is enabled automatically on the evaluation board once VIN is applied. To disable the MP3900, just turn off the power supply or pull COMP low.
7. The output voltage VOUT can be changed by varying R1. Calculate the new value using the formula:  
$$R1 = (V_{out}/V_{fb} - 1)R2$$
Where  $V_{FB} = 0.8V$  and  $R2 = 10k\Omega$   
For example, for  $V_{OUT} = 25V$   
$$R1 = (25/0.8 - 1)10k = 302.5k$$
Therefore use a 301k $\Omega$  standard 1% value.
8. If MOSFET  $R_{ds,on}$  sense is preferred, remove R6 and stuff R7 and R5 with 0 $\Omega$ .

**NOTICE:** The information in this document is subject to change without notice. Users should warrant and guarantee that third party Intellectual Property rights are not infringed upon when integrating MPS products into any application. MPS will not assume any legal responsibility for any said applications.