

### DESCRIPTION

The MP3430 is a monolithic step-up converter with an integrated power switch and a biased avalanche-photodiode (APD) current monitor. The output voltage can be doubled by design through the APD's optical receivers. The MP3430 can provide up to 90V output.

The MP3430 uses a current-mode, fixed-frequency architecture to regulate the output voltage and provide a fast transient response and cycle-by-cycle current limit. The MP3430 features two accurate APD current-monitoring outputs with 1:10 and 1:2 ratios, respectively. Resistor-adjustable current limiting protects the APD from optical power transients.

### ELECTRICAL SPECIFICATION

Parameter	Symbol	Value	Units
Input Voltage	$V_{IN}$	2.7 to 5.5	V
Output Voltage	$V_{OUT}$	50	V
Output Current	$I_{OUT}$	2	mA

### FEATURES

- 2.7V-to-5.5V Input Voltage
- 100V, 0.8Ω NFET with 280mA Limit
- Up to 90V Output Voltage
- 50ns APD Current Monitoring Response Speed
- 1.3MHz Fixed Switching Frequency
- Internal Compensation and Soft Start
- High Side APD Current Monitor with Less Than ±5% Tolerance.
- 1:10 and 1:2 Output Ratios for APD Current Monitoring
- Thermal-Shutdown Protection
- Programmable APD Over-Current Limit and Protection
- 3×3mm QFN16 Package

### APPLICATIONS

- APD Bias
- PIN Diode Bias
- Optical Receivers and Modules
- Fiber Optic Network Equipment

All MPS parts are lead-free and adhere to the RoHS directive. For MPS green status, please visit MPS website under Products, Quality Assurance page. "MPS" and "The Future of Analog IC Technology", are Registered Trademarks of Monolithic Power Systems, Inc.

## EV3430-Q-00A EVALUATION BOARD



FRONT

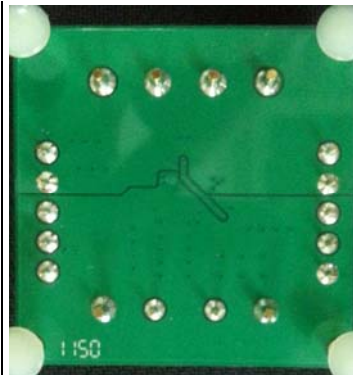

BACK

<b>Board Number</b>	<b>MPS IC Number</b>
EV3430-Q-00A	MP3430GQ

### APD Monitor Current Response Speed

10μA to 1mA Step

$V_{IN} = 3.3V, V_{OUT} = 50V$

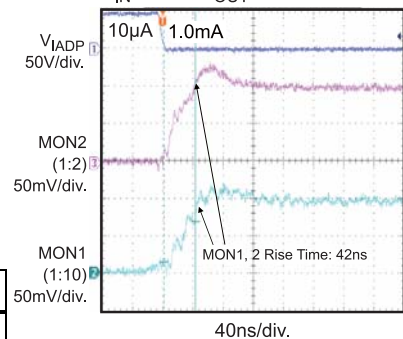

## EVALUATION BOARD SCHEMATIC

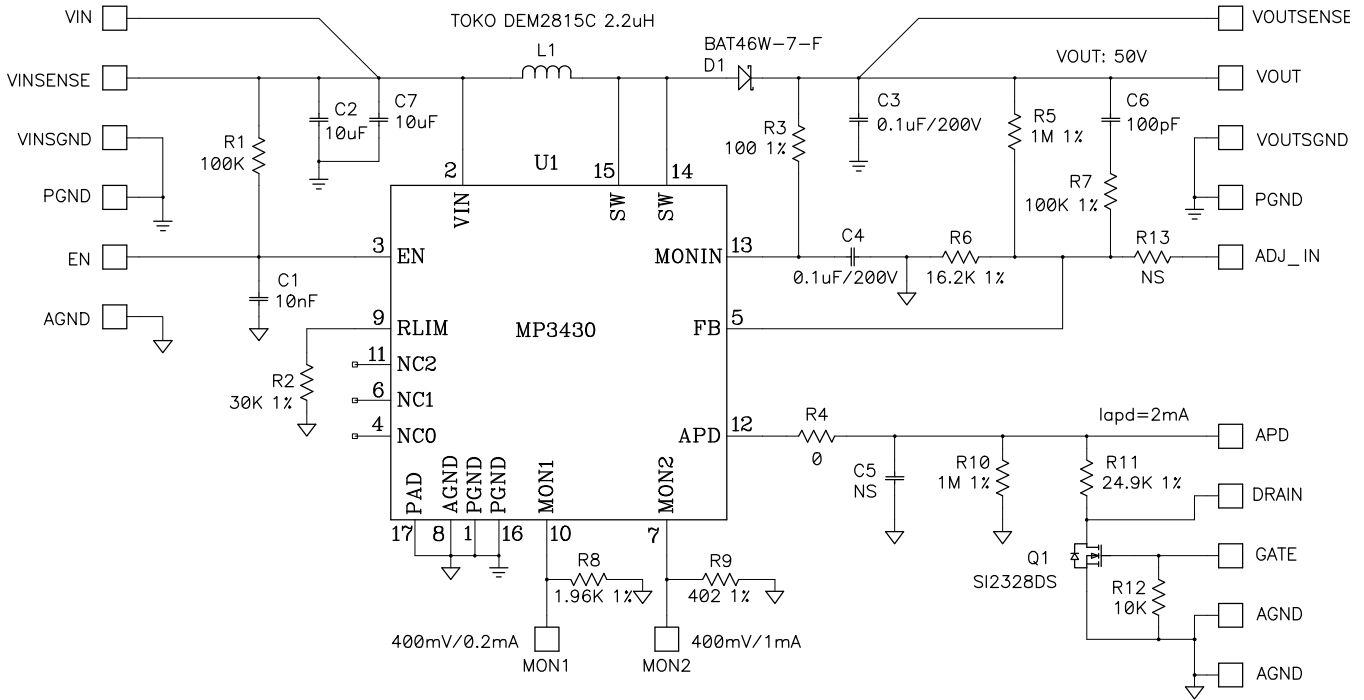

## EV3430-Q-00A BILL OF MATERIALS

Qty	Ref	Value	Description	Package	Manufacturer	Part Number
1	L1	2.2µH	L, Inductor 2.2uH, 1.8A	Type DEM2815C	Toko	1226AS-H-2R2M
1	Q1	XTR	MOSFET N-CH 100V 1.15A SOT23-3	SOT-23-3	Vishay/Siliconix	SI2328DS-T1-E3
1	D1	Diode	DIODE SCHOTTKY 200MW 100V SOD-12	SOD-123	Diodes Inc	BAT46W-7-F
1	C1	10nF	CAP CER 10000PF 16V 10% X7R 0603	0603	muRata	GRM188R71C103 KA01D
2	C2, C7	10µF	CAP CER 10UF 10V 10% X7R 0805	0805	muRata	GRM21BR71A106 KE51L
2	C3, C4	0.1µF	0.1uF/250V/X7R/10%/1210	1210	muRata	GRM32DR72E104 KW01L
1	C5	NS		1210		
1	C6	100pF	CAP CER 100pF/250V/NPO/5%/0805	0805	muRata	GRM21A5C2E101J W01D
1	R1	100kΩ	Film Res., 5%	0603	Yageo	RC0603JR-07100KL
1	R2	30kΩ	Film Res., 1%	0603	Yageo	RC0603FR-0730KL
1	R3	100Ω	Film Res., 1%	0603	Yageo	RC0603FR-07100RL

**EV3430-Q-00A BILL OF MATERIALS (Continued)**

Qty	Ref	Value	Description	Package	Manufacturer	Part Number
1	R4	0Ω	Film Res., Jumper	0603	Yageo	RC0603JR-070RL
2	R5, R10	1MΩ	R <sub>FB</sub> , Top RES 1.00M OHM 1/10W 1% 0603 SMD	0603	Yageo	RC0603FR-071ML
1	R6	16.2kΩ	Film Res., 1%	0603	Yageo	RC0603FR-0716K2L
1	R7	100kΩ	Film Res., 1%	0603	Yageo	RC0603FR-07100KL
1	R8	1.96kΩ	Film Res., 1%	0603	Yageo	RC0603FR-071K96L
1	R9	402Ω	Film Res., 1%	0603	Yageo	RC0603FR-07402RL
1	R11	24.9kΩ	Film Res., 1%	0805	Yageo	RC0805FR-0724K9L
1	R12	10kΩ	Film Res., 5%	0603	Yageo	RC0603JR-0710KL
1	R13		NS	0603		
1	U1		MP3430 APD Boost IC with Internal Switch		MPS	MP3430GQ

## PRINTED CIRCUIT BOARD LAYOUT

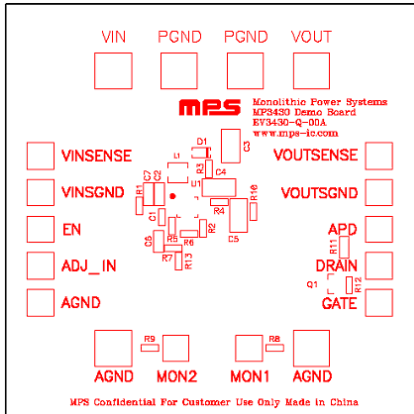

Figure 1—Top Silk Layer

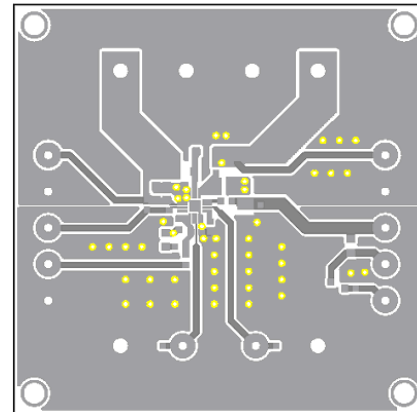

Figure 2—Top Layer

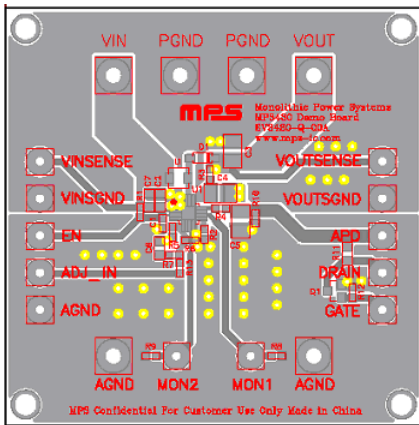

Figure 3—Top Layer with Silk

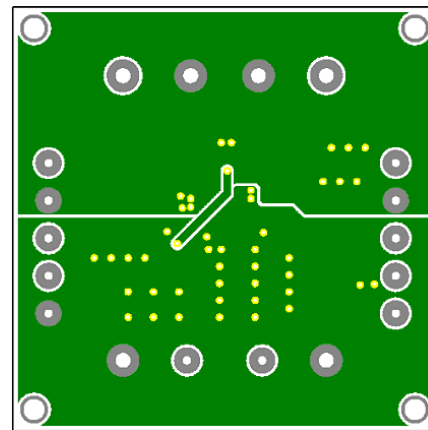

Figure 4—Bottom Layer

## QUICK START GUIDE

- 1) The output voltage of this board is set to 50V
- 2) Preset the power supply to  $2.7V \leq V_{IN} \leq 5.5V$ .
- 3) Turn the power supply off.
- 4) Connect the power supply terminals to:  
Positive (+): VIN  
Negative (-): GND
- 5) Connect the load to:  
Positive (+): APD  
Negative (-): GND
- 6) Make sure the load is  $\leq 2mA$
- 7) Turn the power supply on after making the connections.
- 8) The MP3430 is enabled on the evaluation board once VIN is applied.
- 9) The output voltage VOUT can be changed by varying R6. Calculate the new value using the formula:

$$V_{OUT} = 0.8 \times \left( 1 + \frac{R5}{R6} \right)$$

- 10) The output voltage can be dynamically adjusted through a voltage applied to the ADJ pin. Use the following formula to adjust VOUT:

$$V_{OUT} = 0.8 \times \left( 1 + \frac{R5}{R6} \right) + \left( \frac{R5}{R13} \times (0.8V - ADJ) \right)$$

- 11) The APD current limit can be changed by adjusting R2. The formula is:

$$R_{RLIM} = \frac{68}{I_{APD,MAX}}$$

Where:

$R_{RLIM}$  units = k $\Omega$

$I_{RLIM}$  units = mA

**NOTICE:** The information in this document is subject to change without notice. Please contact MPS for current specifications. Users should warrant and guarantee that third party Intellectual Property rights are not infringed upon when integrating MPS products into any application. MPS will not assume any legal responsibility for any said applications.