

DESCRIPTION

The EV3384EQ-00A is an evaluation board for the MP3384, a step-up converter designed for liquid-crystal displays that employ an array of LEDs as the light source. It can drive 4 strings in parallel and 10 LEDs per string.

The MP3384 uses internal switch current mode, fixed frequency architecture and includes current ballast in each string terminal, which achieves 2.5% current regulation accuracy between strings. Low feedback voltage at each LED string help reduce power loss and improve efficiency.

The MP3384 has multiple features to protect the converter from fault conditions, including under-voltage lockout, current limiting, over voltage, short LED, open LED and thermal shut-down protection.

The MP3384 is available in small QFN16 (3mmx 3mm) package.

ELECTRICAL SPECIFICATIONS

Parameter	Symbol	Value	Units
Input Voltage	V_{IN}	4.5 – 25	V
LEDs #		4 strings parallel and 10 LEDs each string	
LED Current	I_{LED}	20/string	mA

FEATURES

- 4.5V to 25V Input Voltage Range
- Up to 86% Efficiency
- Programmable Over Voltage Protection
- Drives 4 Strings Parallel and 10 LEDs in Series.
- 2.5% Current Regulation Accuracy Between Strings
- Selectable Switching Frequency: 1.25MHz and 625kHz
- Open and Short LED Load Protection
- Thermal Shutdown

APPLICATIONS

- Note Book
- Net Book
- Digital Picture Frames
- Handy Terminals Display
- Automotive Systems and Tablet Computer

For MPS green status, please visit MPS website under Quality Assurance. "MPS" and "The Future of Analog IC Technology" are Registered Trademarks of Monolithic Power Systems, Inc.

EV3384EQ-00A EVALUATION BOARD

(L x W x H) 2mm x 4.8mm x 1.0mm

Board Number	MPS IC Number
EV3384EQ-00A	MP3384EQ

EVALUATION BOARD SCHEMATIC

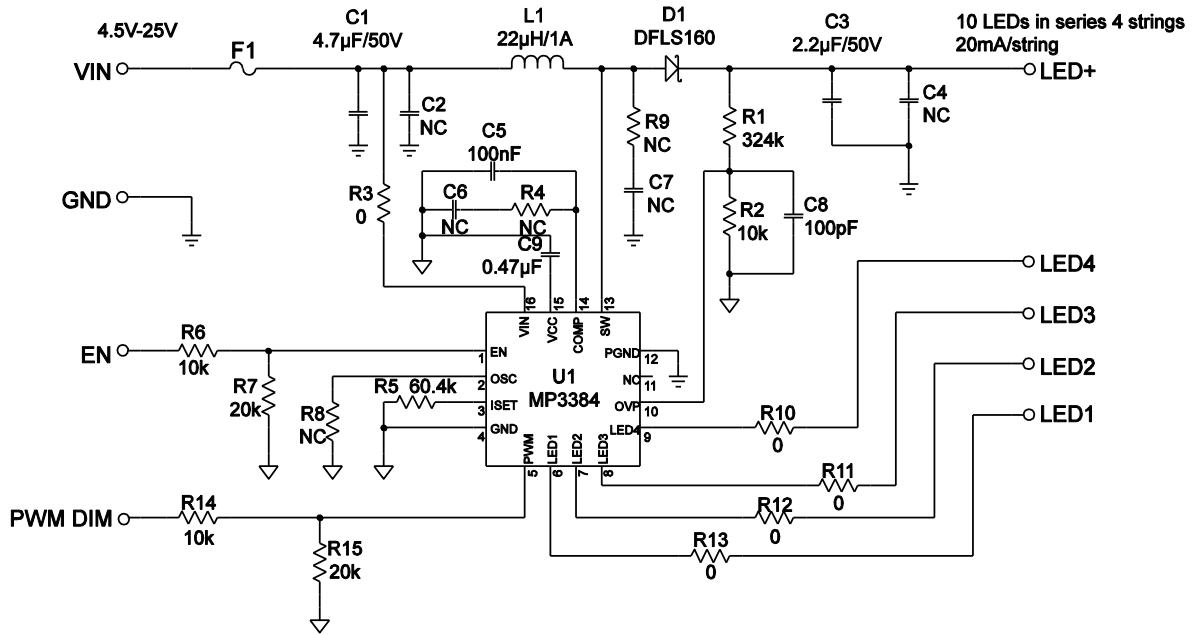

EV3384EQ-00A BILL OF MATERIALS

Qty	Ref	Value	Description	Package	Manufacturer	Part Number
1	C1	4.7 μ F	Ceramic Capacitor, 50V, X7R	1210	Murata	GRM32ER71H475KA8
2	C2,C4	NC		1210		
1	C3	2.2 μ F	Ceramic Capacitor, 50V, X7R	1210	Murata	GRM32ER72A225KA3
1	C5	100nF	Ceramic Capacitor, 50V, X7R	0603	Murata	GRM188R71H104KA0
2	C6,C7	NC		0603		
1	C8	100pF	Ceramic Capacitor, 50V, X7R	0603	Murata	GRM188R71H101KA9
1	C9	0.47 μ F	Ceramic Capacitor, 16V, X5R	0603	Murata	GRM21BR61C474KA8
1	D1		Diode Schottky, 60V, 1A	SMA	Diodes Inc	DFLS160-F
1	F1	0 Ω	Resistor, 5%	1206	Yageo	RC1206JR-070RL
1	L1	22 μ H	Inductor,1A	SMD	Wurth	7440700220
		33 μ H	Inductor,1.4A	SMD	TOKO	DS85LCB-B1135AS-330M
1	R1	324k Ω	Resistor, 1%	0603	Yageo	RC0603FR-07324KL
1	R2	10k Ω	Resistor, 1%	0603	Yageo	RC0603FR-0710KL
5	R3,R10~R13	0 Ω	Resistor, 5%	0603	Yageo	RC0603JR-070RL
3	R4,R8,R9	NC		0603		
1	R5	60.4k Ω	Resistor, 1%	0603	Yageo	RC0603FR-0760K4L
2	R6,R14	2k Ω	Resistor, 5%	0603	Yageo	RC0603JR-072KL
2	R7,R15	20k Ω	Resistor, 5%	0603	Yageo	RC0603JR-0720KL
1	U1		LED Driver IC	QFN(3x3)	MPS	MP3384EQ

PRINTED CIRCUIT BOARD LAYOUT

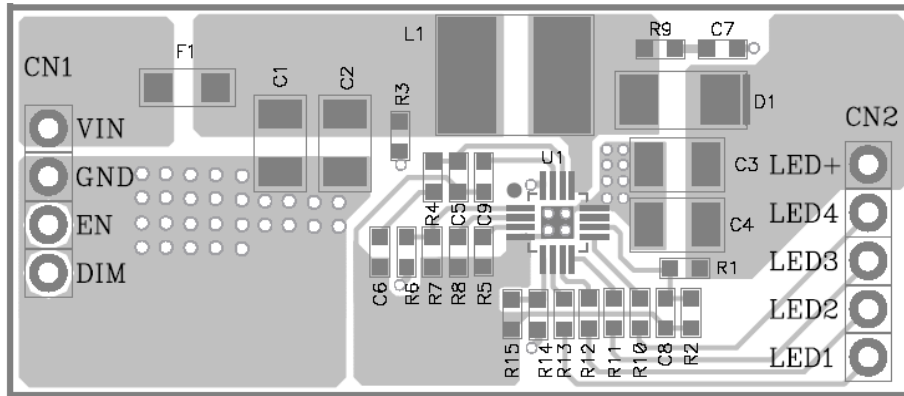

Figure 1—Top Layer

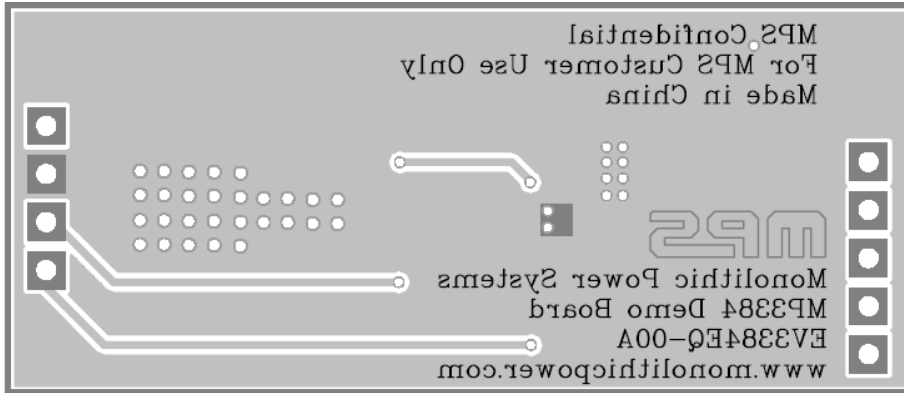

Figure 2—Bottom Layer

QUICK START GUIDE

1. Connect the positive and negative terminals of the load panel (10 white LEDs in series, 4 strings paralleled) to the LED+ and LED1~4 pins on the EV board, respectively.
2. Connect the positive and negative terminals of the power supply (4.5V ~ 25V) to the VIN and GND pins on the EV board, respectively.
3. Drive EN pin high ($2.5V < V_{en} < 5V$) to enable the MP3384.
4. For PWM dimming, apply a PWM rectangular waveform with a minimum voltage less than 0.8V and a maximum greater than 1.5V on PWM DIM pin. The frequency of the PWM signal is recommended between 200Hz to 2kHz.

NOTICE: The information in this document is subject to change without notice. Users should warrant and guarantee that third party Intellectual Property rights are not infringed upon when integrating MPS products into any application. MPS will not assume any legal responsibility for any said applications.