

DESCRIPTION

The EV3212DQ-00A is the evaluation board of MP3212, a constant frequency, 10-pin QFN current mode step-up converter intended for small, low power applications. The EV3212DQ operates from an input voltage as low as 2.3V and can generate as high as 28V output voltage and up to 100mA output current.

The EV3212 features PFM at light loads for high efficiency. The EV3212 includes under-voltage lockout, output over-voltage protection, current limiting, and thermal overload protection to prevent damage in the event of an output overload.

ELECTRICAL SPECIFICATIONS

Parameter	Symbol	Value	Units
Supply Voltage	V_{IN}	2.3 to 5.5	V
Output Current	I_{OUT}	0 to 100	mA

FEATURES

- 180 μ A Quiescent Current
- 2.3V to 5.5V Input Voltage
- 1MHz Fixed Switching Frequency
- 1.3A Switch Current Limit
- Input-output disconnect
- Up to 28V Output Voltage
- Automatic Pulse Frequency Modulation Mode at Light Loads
- Over 85% Efficiency
- Available in a 10-Pin QFN Package

APPLICATIONS

- OLED Biasing
- LCD Bias Supply
- White LED Driver
- PDAs
- Digital Still Cameras

"MPS" and "The Future of Analog IC Technology" are Registered Trademarks of Monolithic Power Systems, Inc.

EV3212DQ-00A EVALUATION BOARD



Board Number	MPS IC Number
EV3212DQ-00A	MP3212DQ

Efficiency vs. Load Current

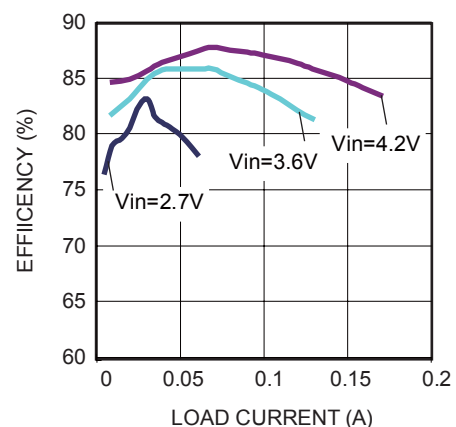

EVALUATION BOARD SCHEMATIC

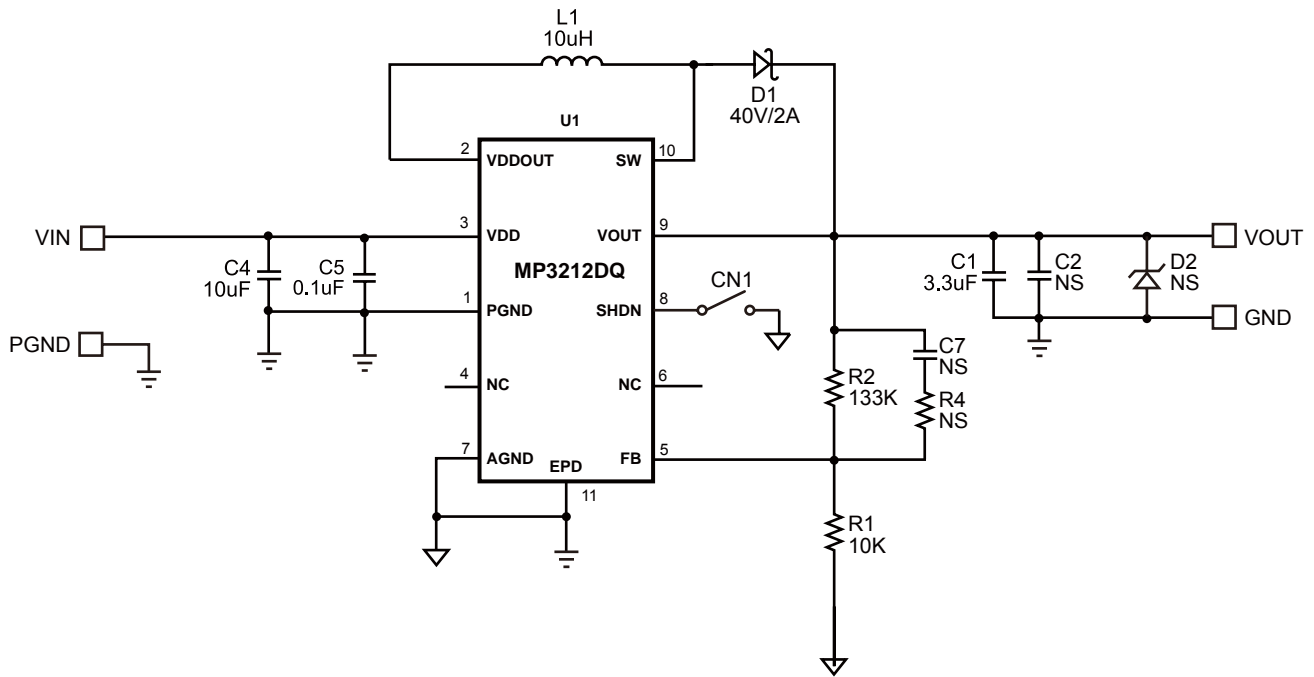

EV3212DQ-00A BILL OF MATERIALS

Qty	Ref	Value	Description	Package	Manufacturer	Manufacturer P/N
1	C1	3.3uF	Ceramic Cap., 50V, X7R	1210	Murata	GRM32DR71H335KA88L
2	C2,C7	NS				
1	C4	10uF	Ceramic Cap., 16V, X7R	1206	Murata	GRM31CR71C106KA64L
1	C5	0.1uF	Ceramic Cap., 16V, X7R	0603	Murata	GRM188R71C104KA01D
1	R1	10KΩ	Film Resistor, 1%	0603	Yageo	RC0603FR-0710K0L
1	R2	133KΩ	Film Resistor, 1%	0603	Yageo	RC0603FR-0133K0L
1	D1	2A,40V	Schottky Diode	SMA	Diode Inc	B240A-13-F
1	D2	NS				
1	CN1		2-Pin Header,0.1"		Sullins	PTC02SAAN
1	Jumper	Short	2 PIN 2.54mm Short Jumper	0.1"	Sullins	STC02SYAN
1	L1	10 uH	Inductor, Idc=2.7A, DCR=71mΩ	8x8x4mm	TOKO	B1015AS-100M
1	U1		Step-down Regulator	QFN10	MPS	MP3212DQ-R1

PRINTED CIRCUIT BOARD LAYOUT

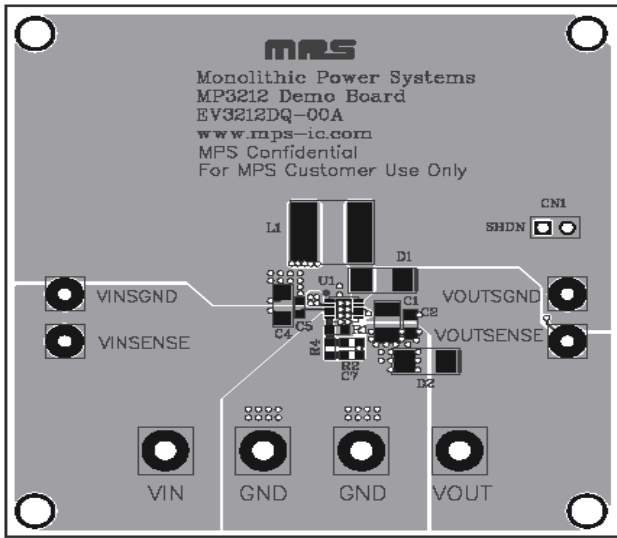

Figure 1—Top and Top Silk Layer

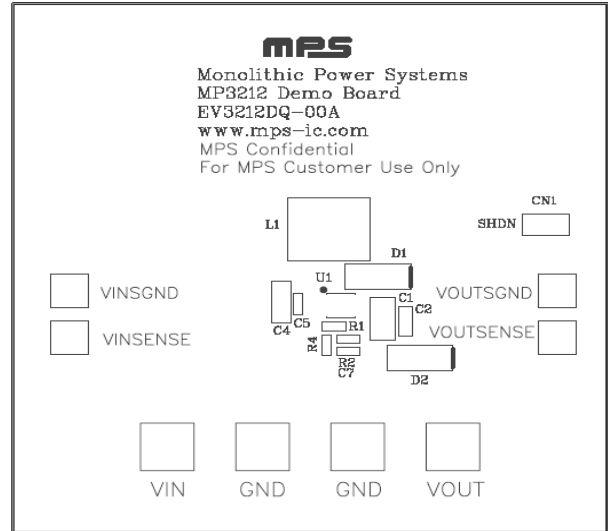

Figure 2—Top Silk Layer

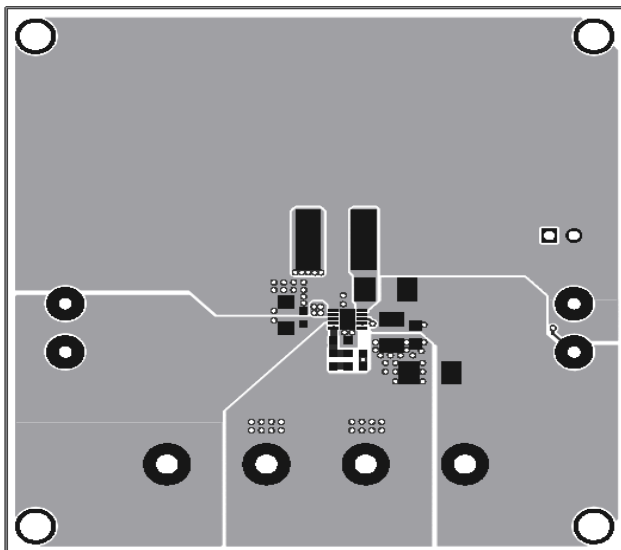

Figure 3—Top Layer

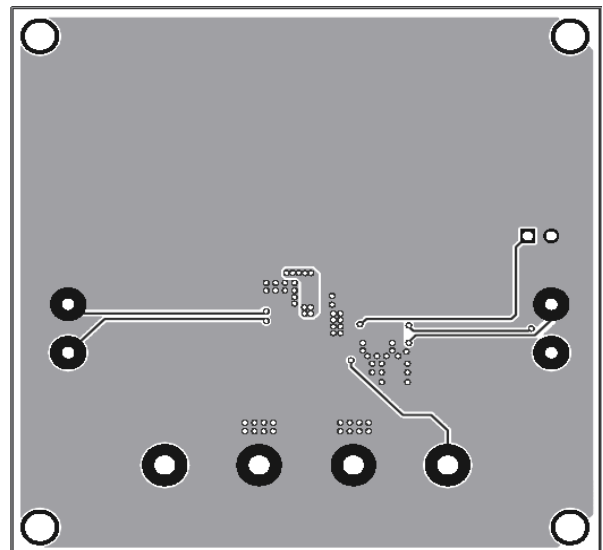

Figure 4—Bottom Layer

QUICK START GUIDE

The output voltage of this board is set to 18V. The board layout accommodates most commonly used inductors and output capacitors.

1. Preset Power Supply to $2.5V \leq V_{IN} \leq 5.5V$.
2. Turn Power Supply off.
3. Connect Power Supply terminals to:
Positive (+): V_{IN}
Negative (-): GND
4. Connect Load to:
Positive (+): V_{OUT}
Negative (-): GND
5. Turn Power Supply on after making connections.
6. The MP3212 is enabled on the evaluation board once V_{IN} is applied. To disable the MP3212, disconnect CN1.
7. The output voltage V_{OUT} can be changed by varying R2. Calculate the new value using the formula:

$$R2 = \left(\frac{V_{OUT}}{V_{FB}} - 1 \right) \times R1$$

Where $V_{FB} = 1.24V$ and $R1 = 10k\Omega$

For example, for $V_{OUT} = 18V$

$R2 = (18V/1.24V - 1) \times 10k\Omega = 135.2k\Omega$

Therefore use a 133k Ω standard 1% value resistor.

NOTICE: The information in this document is subject to change without notice. Please contact MPS for current specifications. Users should warrant and guarantee that third party Intellectual Property rights are not infringed upon when integrating MPS products into any application. MPS will not assume any legal responsibility for any said applications.