



The Future of Analog IC Technology®

EV2905EK-00B

1.2V, 20A, 300kHz, Hysteretic Synchronous Step-Down Controller Evaluation Board

DESCRIPTION

The EV2905EK-00B is the evaluation board for the MP2905EK, a hysteretic synchronous step-down controller. It offers a very compact solution to achieve 1.2V, 20A continuous output current from a 10.8V to 13.2V input voltage range over a wide operation input voltage. An adjustable soft-start prevents inrush current at turn-on.

Hysteretic voltage control can provide fast transient without any loop compensation. Full protection features include OCP, output OVP, thermal shut down.

The EV2905EK frequency is approximately 300kHz (12V input). Peak Current limit is set at 32A. The efficiency is up to 90% (12V input) with the supplied components.

ELECTRICAL SPECIFICATIONS

Parameter	Symbol	Value	Units
Input Voltage	V _{IN}	10.8 - 13.2V	V
Output Voltage	V _{OUT}	1.2	V
Hold Current	I _{OUT}	20 ⁽²⁾	A

FEATURES

- 20A output current, 1.2V output voltage
- Programmable Soft-Start
- Hiccup current limit and thermal shut down
- Monotonic Startup into Prebias Output
- Startup Overvoltage Protection
- Enable/Shutdown

APPLICATIONS

- Motherboard Power Supplies
- AGP and PCI-Express Power Supplies
- Graphic-Card Power Supplies
- Set-Top Boxes
- Point-of-Load Power Supplies

Notes:

- 1) Circuit can work up to about 20A over a wide input voltage range. This EVB shows the performance at 12V input. So the frequency and current limit are designed for the 12V application
- 2) The max load can be up to 25A, but the thermal performance is not good enough at 25A, so recommend to works at 20A.

"MPS" and "The Future of Analog IC Technology" are Registered Trademarks of Monolithic Power Systems, Inc.

EV2905EK-00B EVALUATION BOARD



(L x W x H) 2.5" x 2.5" x 0.63"
(6.3cm x 6.3cm x 1.6cm)

Board Number	MPS IC Number
EV2905EK-00B	MP2905EK

Efficiency

V_{IN}=12V, V_{OUT}=1.2V

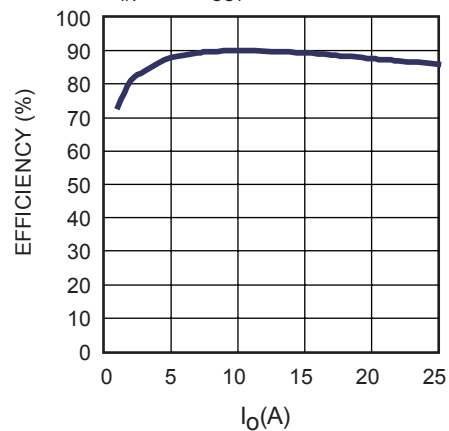

EVALUATION BOARD SCHEMATIC

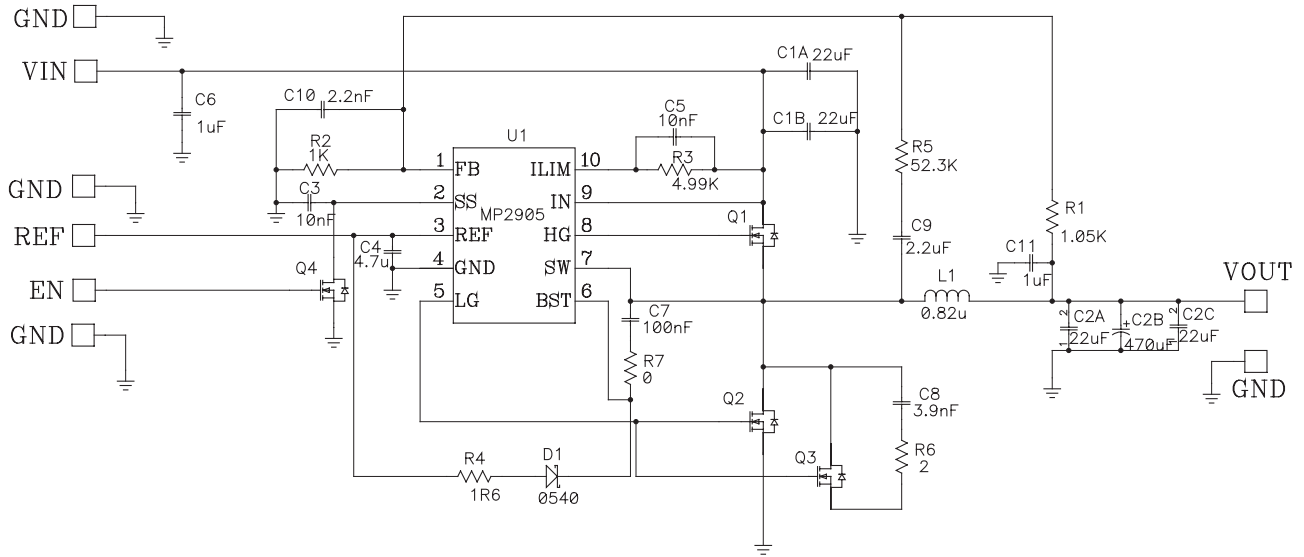

EV2905EK-00B BILL OF MATERIALS

Qty	RefDes	Value	Description	Package	Manufacturer	Manufacturer P/N
2	C1A,C1B	22uF	Ceramic Cap,25V,X5R	1210	Murata	GRM32ER61E226KE15L
2	C2A,C2C	22uF	Ceramic Cap,16V,X5R	1210	Murata	GRM32DR60J226KA0
1	C2B	470uF	Poscap,2.5V	Poscap	Sanyo	2R5TPE470M9
2	C3,C5	10nF	Ceramic Cap,50V,X7R	0603	TDK	C1608X7R1H103K
1	C4	4.7uF	Ceramic Cap,10V,X5R	0805	TDK	C2012X5R1A475K
1	C6	1uF	Ceramic Cap,50V,X7R	0805	Murata	GRM21BR71H105KA12L
1	C7	100nF	Ceramic Cap,50V,X7R	0603	TDK	C1608X7R1H104K
1	C8	3.9nF	Ceramic Cap,50V,X7R	0603	Murata	GRM188R71H392KA01D
1	C9	2.2uF	Ceramic Cap,10V,X7R	0603	Murata	GRM188R71A225KE15
1	C10	2.2nF	Ceramic Cap,50V,X7R	0603	TDK	C1608X7R1H222K
1	C11	1uF	Ceramic Cap,16V,X7R	0603	Murata	GRM188R71C105KA12D
1	R1	1.05K	Film Res,1%	0603	Yageo	RC0603FR-071K05L
1	R2	1K	Film Res,1%	0603	Yageo	RC0603FR-071KL
1	R3	4.99K	Film Res,1%	0603	Yageo	RC0603FR-074K99L
1	R4	1.6	5%	0603	Yageo	RC0603JR-071R6L
1	R5	52.3K	Film Res,1%	0603	Yageo	RC0603FR-0752K3L
1	R6	2	Film Res,5%	0603		
1	R7	0	Film Res,5%	0603		
1	Q1		SiR460DP-T1-GE3, 30V,40A, Rds_on=6.1mΩ@4.5Vgs, Qg=16.8nC, tr=16ns,tf=12ns@4.5Vgen	PowerPAK SO-8	Vishay	SiR460DP-T1-GE3
2	Q2,Q3		AP2R403GMTHF, 30V,130A, Rds_on=3.8mΩ@4.5Vgs, Qg=20.5nC	PowerPAK SO-8	Apec	AP2R403GMT-HF
1	Q4		2N7002(60V,115mA)	SOT-23	Diodes	2N7002(60V,115mA)
1	D1		B0540W, 30V, 0.5A	SOD-123	Diodes	B0540W
1	L1	0.82uH	Inductor, Rated current=27A, Saturation current=35A, DCR=0.9mΩ,	SMT	Würth	744355182
1	U1		MP2905	MSOP10	MPS	MP2905

PRINTED CIRCUIT BOARD LAYOUT

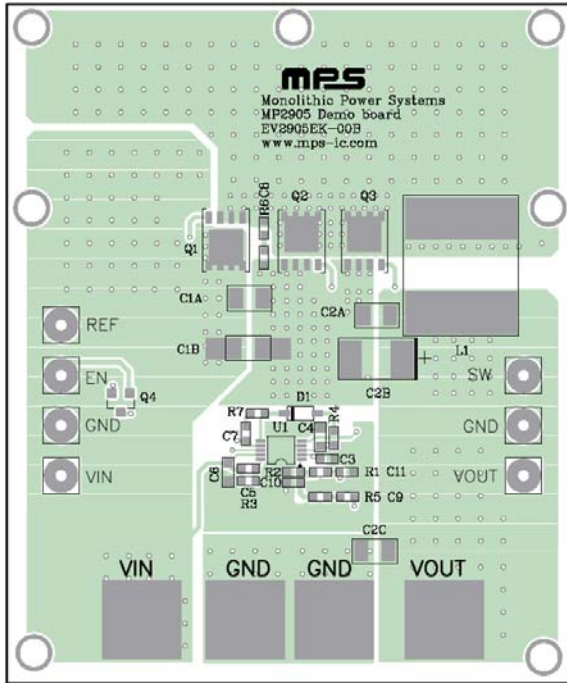

Figure 1—Top Layer

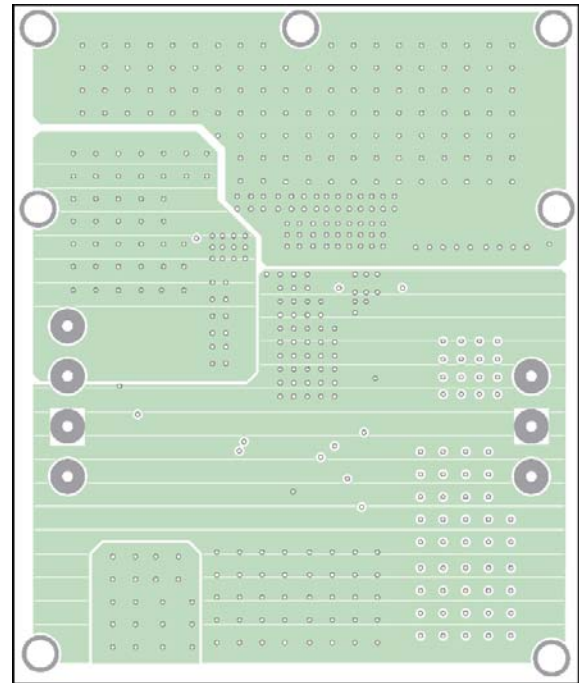

Figure 2—IN1 Layer

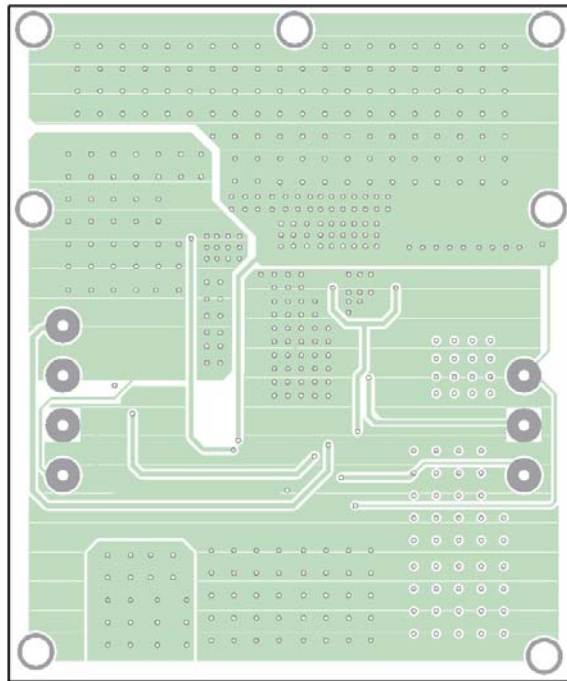

Figure 3—IN2 Layer

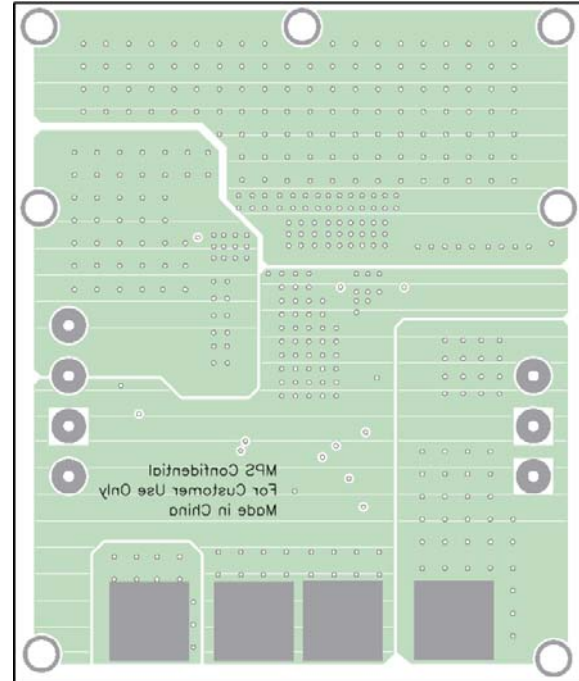

Figure 4—Bottom Layer

QUICK START GUIDE

1. Stuff multi-strand wire in VOUT, VOUT_GND pad and single strand wire in VIN, VIN_GND pad.
2. Connect the positive terminal of the load to VOUT multi-strand wire, and the negative terminal of the load to GND multi-strand wire.
3. Preset the power supply output to 12V and turn it off.
4. Connect the positive terminal of the power supply output to the VIN wire and the negative terminal of the power supply output to the GND wire.
5. Connect the EN pin to GND.
6. Turn the power supply on. The MP2905EK will automatically startup.
7. To use the Enable function, drive EN higher than 4V to turn on the MOS Q4, then SS is pulled down, part shuts down. Drive EN less than 0.5V to turn off the MOS Q4, then SS is released, part turns on. Do not float EN pin.
8. The output voltage VOUT can be programmed by R1 and R2. Calculate the new value using the formula:

$$R1 = R2 \times \left(\frac{V_{OUT}}{V_{FB}} - 1 \right)$$

Where $V_{FB}=0.59V$.

In order to get good transient, R1 and R2 should be small enough. Always set R2=1kΩ or smaller, and R1 is not higher than 3 kΩ.

9. The frequency is set by C10 and R5. C10 should not be small enough to get good transient response, 2.2nF is recommended , then R5 is used to program the frequency by formula below:

$$R_{10} = \frac{\frac{V_{out} \times (V_{IN} - V_{OUT})}{f} - V_{IN} \times (90ns \times V_{IN} - 20ns \times V_{OUT})}{V_{IN} \times C_5 \times V_{HY}}$$

Where V_{HY} is output regulation hysteresis, typical value is 22mV.

10. The EV board is designed for 12V input, 1.2Vout application. So, for other application, some parameters such as current limit and frequency need to be redesigned. Please refer to AN023 to set related parameters.

NOTICE: The information in this document is subject to change without notice. Users should warrant and guarantee that third party Intellectual Property rights are not infringed upon when integrating MPS products into any application. MPS will not assume any legal responsibility for any said applications.