



The Future of Analog IC Technology®

EV2905A-K-01A

1.2V, 10A, 300kHz, Hysteretic Synchronous Step-Down Controller Evaluation Board

DESCRIPTION

The EV2905A-K-01A is the evaluation board for the MP2905AEK, a hysteretic synchronous step-down controller. It offers a very compact solution to achieve 1.2V, 10A continuous output current from a 10.8V to 13.2V input voltage range over a wide operation input voltage. An adjustable soft-start prevents inrush current at turn-on.

Hysteretic voltage control can provide fast transient without any loop compensation. Full protection features include OCP, output OVP, thermal shut down.

The EV2905A-K-01A frequency is approximately 300kHz (12V input). Peak Current limit is set at 15A. The efficiency is up to 90% (12V input) with the supplied components.

ELECTRICAL SPECIFICATIONS

Parameter	Symbol	Value	Units
Input Voltage	V_{IN}	10.8 - 13.2V	V
Output Voltage	V_{OUT}	1.2	V
Load Current	I_{OUT}	10 ⁽¹⁾	A

FEATURES

- 10A Output Current, 1.2V Output Voltage
- Programmable Soft-Start
- Hiccup Current Limit and Thermal Shutdown
- Monotonic Startup into Prebias Output
- Startup Overvoltage Protection
- Enable/Shutdown

APPLICATIONS

- Motherboard Power Supplies
- AGP and PCI-Express Power Supplies
- Graphic-Card Power Supplies
- Set-Top Boxes
- Point-of-Load Power Supplies

Notes:

- 1) Circuit can work up to about 10A over a wide input voltage range. This EVB shows the performance at 12V input. So the frequency and current limit are designed for the 12V application

"MPS" and "The Future of Analog IC Technology" are Registered Trademarks of Monolithic Power Systems, Inc.

EV2905A-K-01A EVALUATION BOARD

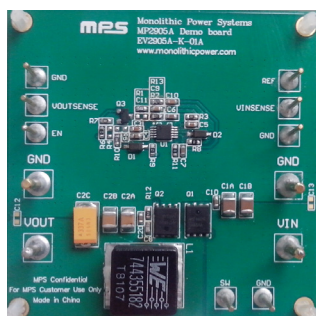

(L x W x H) 2.5" x 2.5" x 0.63"
(6.3cm x 6.3cm x 1.6cm)

Board Number	MPS IC Number
EV2905A-K-01A	MP2905AEK

Efficiency

$V_{IN}=12V, V_{OUT}=1.2V$

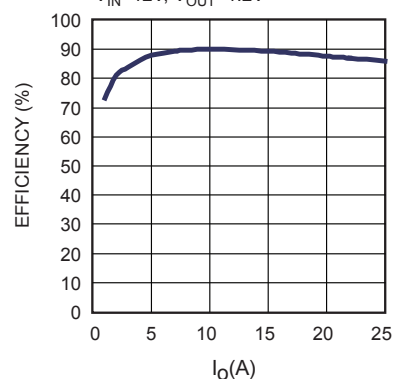

EVALUATION BOARD SCHEMATIC

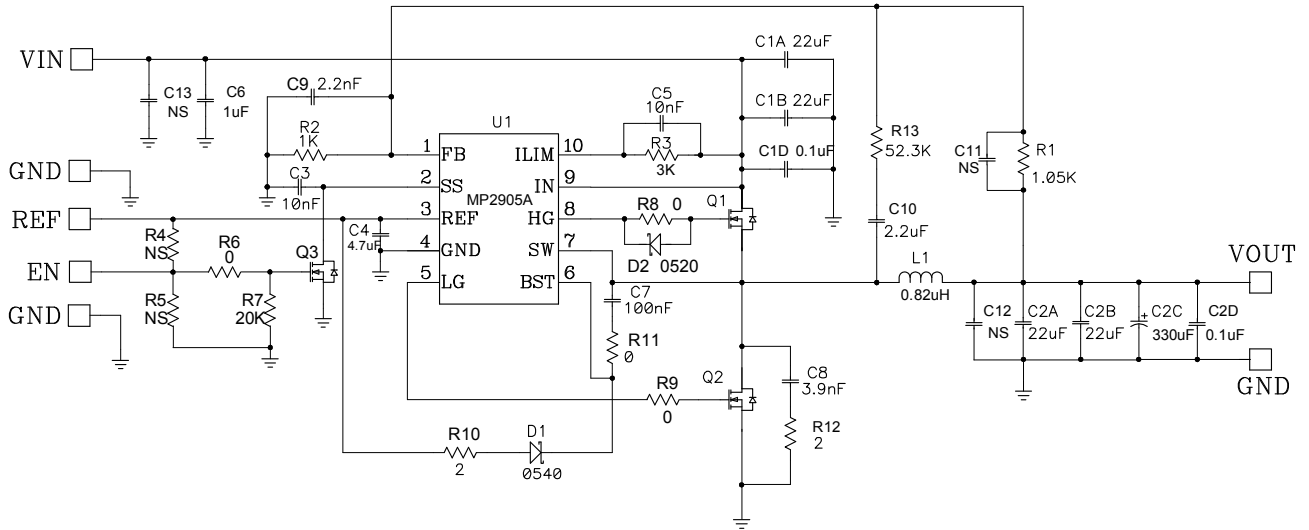

EV2905A-K-01A BILL OF MATERIALS

Qty	RefDes	Value	Description	Package	Manufacturer	Manufacturer P/N
2	C1A,C1B	22 μ F	Ceramic Cap, X5R, 25V	1210	muRata	GRM32ER61E226KE15L
2	C2A,C2B	22 μ F	Ceramic Cap, X5R, 16V	1210	muRata	GRM32ER61C226KE20L
1	C2C	330 μ F	Poscap, 6.3V	Poscap	Sanyo	6TPE330MIL
2	C1D,C2D	0.1 μ F	Ceramic Cap, X7R, 25V	0603	muRata	GRM188R71E104KA01D
2	C3,C5	10nF	Ceramic Cap, X7R, 50V	0603	muRata	GRM188R71H103KA01D
1	C4	4.7 μ F	Ceramic Cap, X5R, 6.3V	0603	muRata	GRM188R60J475KE19D
1	C6	1 μ F	Ceramic Cap, X7R, 25V	0603	muRata	GRM188R71E105KA12D
1	C7	0.1 μ F	Ceramic Cap, X7R, 50V	0603	muRata	GRM188R71H104KA93D
1	C8	3.9nF	Ceramic Cap, X7R, 50V	0603	muRata	GRM188R71H392KA01D
1	C9	2.2nF	Ceramic Cap, X7R, 50V	0603	muRata	GRM1885R71H222A01D
1	C10	2.2 μ F	Ceramic Cap, X7R, 10V	0603	muRata	GRM188R71A225KE15D
	C11	NS				
	C12,C13	NS				
1	R1	1.05k Ω	Film Res, 1%	0603	ROYAL	RL0603FR-071K05L
1	R2	1k Ω	Film Res, 1%	0603	ROYAL	RL0603FR-071KL
1	R3	3k Ω	Film Res, 1%	0603	ROYAL	RL0603FR-03KL
	R4,R5	NS				
4	R6,R8 R9,R11	0 Ω	Film Res, 1%	0603	Yageo	RC0603FR-070RL
1	R7	20k Ω	Film Res, 1%	0603	ROYAL	RL0603FR-0720KL
2	R10,R12	2 Ω	Film Res, 1%	0603	Yageo	RL0603FR-072RL
1	R13	52.3k Ω	Film Res, 1%	0603	ROYAL	RL0603FR-0752K3L
1	D1		B0540W,40V,0.5A	SOD123	Diodes	B0540W
1	D2		B0520LW-7-F,20V,0.5A	SOD323	Diodes	B0520LW-7-F
1	L1	0.82 μ H	Inductor, Rated current=27A, Saturation current=35A, DCR=0.9m Ω	SMT	Wruth	744355182
2	Q1,Q2		AM7432N,30V,27A, Rd _{s_on} =4.9m Ω @4.5Vgs, Qg=25nC, tr=13ns, tf=43ns@4.5Vgen	PowerPAK SO-8	Analog Power	AM7432N
1	Q3		2N7002(60V,115mA)	SOT-23	Diodes	2N7002(60V,115mA)
1	U1	MP2905A	Synchronous Step-Down Controller	MSOP10	MPS	MP2905AEK

PRINTED CIRCUIT BOARD LAYOUT

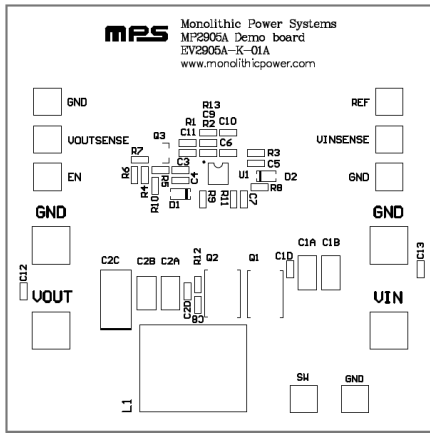

Figure 1—Top Silk Layer

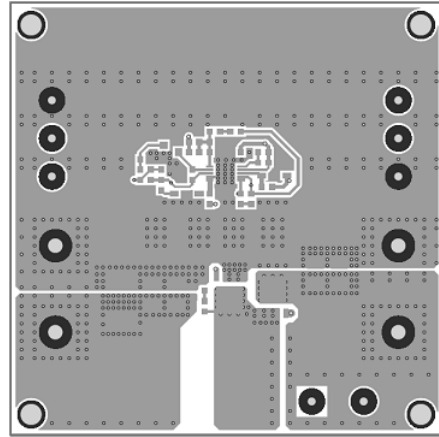

Figure 2—Top Layer

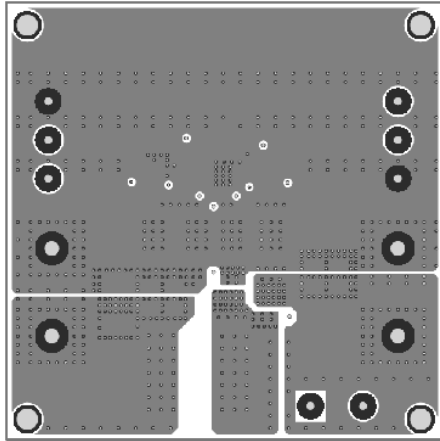

Figure 3—Inner 1 Layer

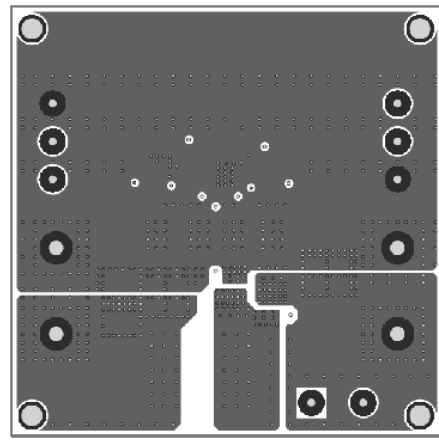

Figure 4—Inner 2 Layer

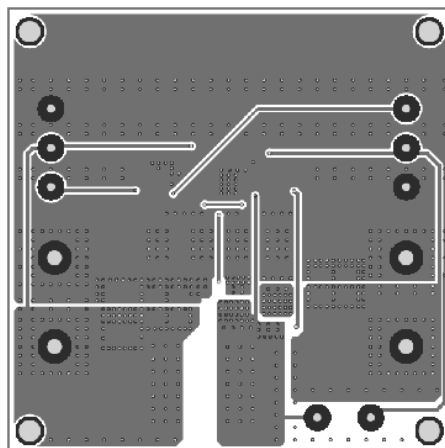

Figure 5—Bottom Layer

QUICK START GUIDE

1. Stuff multi-strand wire in VOUT, VOUT_GND pad and single strand wire in VIN, VIN_GND pad.
2. Connect the positive terminal of the load to VOUT multi-strand wire, and the negative terminal of the load to GND multi-strand wire.
3. Preset the power supply output to 12V and turn it off.
4. Connect the positive terminal of the power supply output to the VIN wire and the negative terminal of the power supply output to the GND wire.
5. Connect the EN pin to GND.
6. Turn the power supply on. The MP2905AEK will automatically startup.
7. To use the Enable function, drive EN higher than 4V to turn on the MOS Q3, then SS is pulled down, part shuts down. Drive EN less than 0.5V to turn off the MOS Q3, then SS is released, part turns on. Do not float EN pin.
8. The output voltage VOUT can be programmed by R1 and R2. Calculate the new value using the formula:

$$R1 = R2 \times \left(\frac{V_{OUT}}{V_{FB}} - 1 \right)$$

Where $V_{FB}=0.59V$.

In order to get good transient, R1 and R2 should be small enough. Always set R2=1kΩ or smaller, and R1 is not higher than 3 kΩ.

9. The frequency is set by C9 and R13. C9 should not be small enough to get good transient response, 2.2nF is recommended, then R13 is used to program the frequency by formula below:

$$R_{13} = \frac{\frac{V_{out} \times (V_{IN} - V_{OUT})}{f} - V_{IN} \times (90ns \times V_{IN} - 20ns \times V_{OUT})}{V_{IN} \times C_9 \times V_{HY}}$$

Where V_{HY} is output regulation hysteresis, typical value is 22mV.

10. The EV board is designed for 12V input, 1.2Vout application. So, for other application, some parameters such as current limit and frequency need to be redesigned. Please refer to AN023 to set related parameters.

NOTICE: The information in this document is subject to change without notice. Users should warrant and guarantee that third party Intellectual Property rights are not infringed upon when integrating MPS products into any application. MPS will not assume any legal responsibility for any said applications.