

DESCRIPTION

The EV2676EG-00A is an evaluation board for the MP2676, the high-performance protection chip with an integrated P-MOSFET for single cell Li-Ion/Li-Polymer battery charger.

By integrating high voltage input protection into the IC, the MP2676 can tolerate an input surge up to 30V.

The MP2676 features input over voltage protection (OVP), battery over voltage protection (BOVP), and over charge current protection (OCP). Additionally, MP2676 also monitors its own internal temperature and provides thermal protection (OTP). It integrates a P-MOSFET with the body diode reverse protection. The P-MOSFET is controlled by the PMU in the system to realize the charging process to charge the battery.

ELECTRICAL SPECIFICATION

Parameter	Symbol	Value	Units
Input Voltage	V_{IN}	5	V
Limit Current	I_{LIM}	1.6	A

FEATURES

- Input Surge up to 30V
- No External Blocking Diode Requiring
- Input Over-Voltage Protection in 1us.
- Input Over-Current Protection
- Battery Over-Voltage Protection
- Temperature Monitoring and Protection
- High Immunity of False Triggering under Start up or Transients

APPLICATIONS

- Cell Phones
- MP3 Players
- Smart Phones
- PDAs
- Digital Cameras
- Desktop Chargers

"MPS" and "The Future of Analog IC Technology" are Registered Trademarks of Monolithic Power Systems, Inc.

EV2676EG-00A EVALUATION BOARD



(L x W x H) 2.5" x 2.5" x 0.4" (6.35cm x 6.35cm x 1.1cm)

Board Number	MPS IC Number
EV2676EG-00A	MP2676EG

EVALUATION BOARD SCHEMATIC

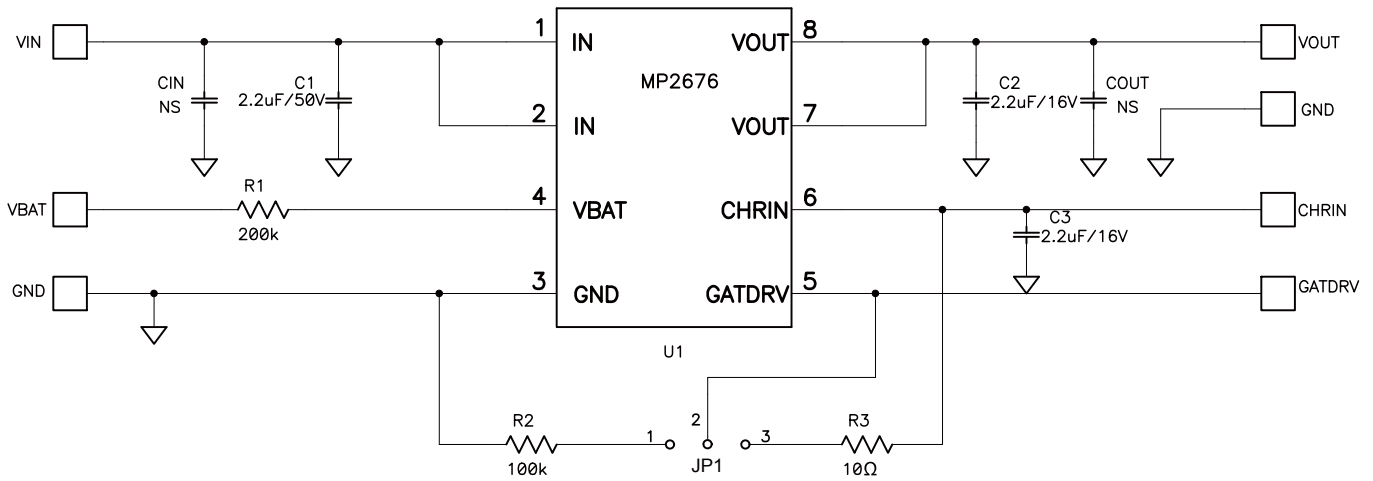

EV2676EG-00A BILL OF MATERIALS

Qty	Ref	Value	Description	Package	Manufacturer	Manufacturer P/N
1	C1	2.2µF	Ceramic Capacitor X7R, 50V	1206	muRata	GRM31CR71H225KA8
1	C2	2.2µF	Ceramic Capacitor X5R, 16V	0805	muRata	GRM21BR61C225KA8
1	C3	2.2µF	Ceramic Capacitor X5R, 16V	0805	muRata	GRM21BR61C225KA8
1	C _{IN}	NS				
1	C _{OUT}	NS				
1	R1	200kΩ	Film Res, 5%	0603	Any	
1	R2	100kΩ	Film Res, 5%	0603	Any	
1	R3	10Ω	Film Res, 5%	0603	Any	
1	U1		Li-ion Charger Protection IC with integrated P-MOSFET	QFN8 2*2(No thermal pad)	MPS	MP2676EG

PRINTED CIRCUIT BOARD LAYOUT

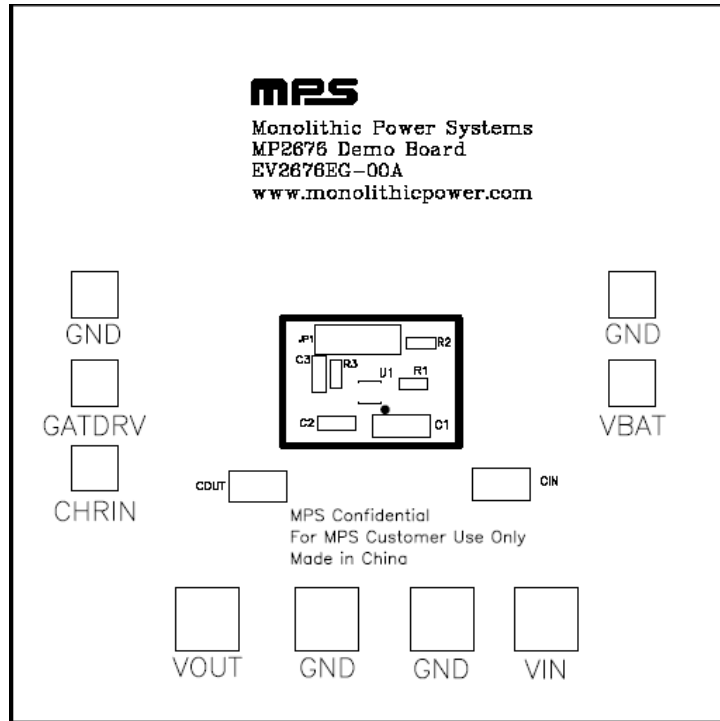

Figure 1—Top Silk Layer

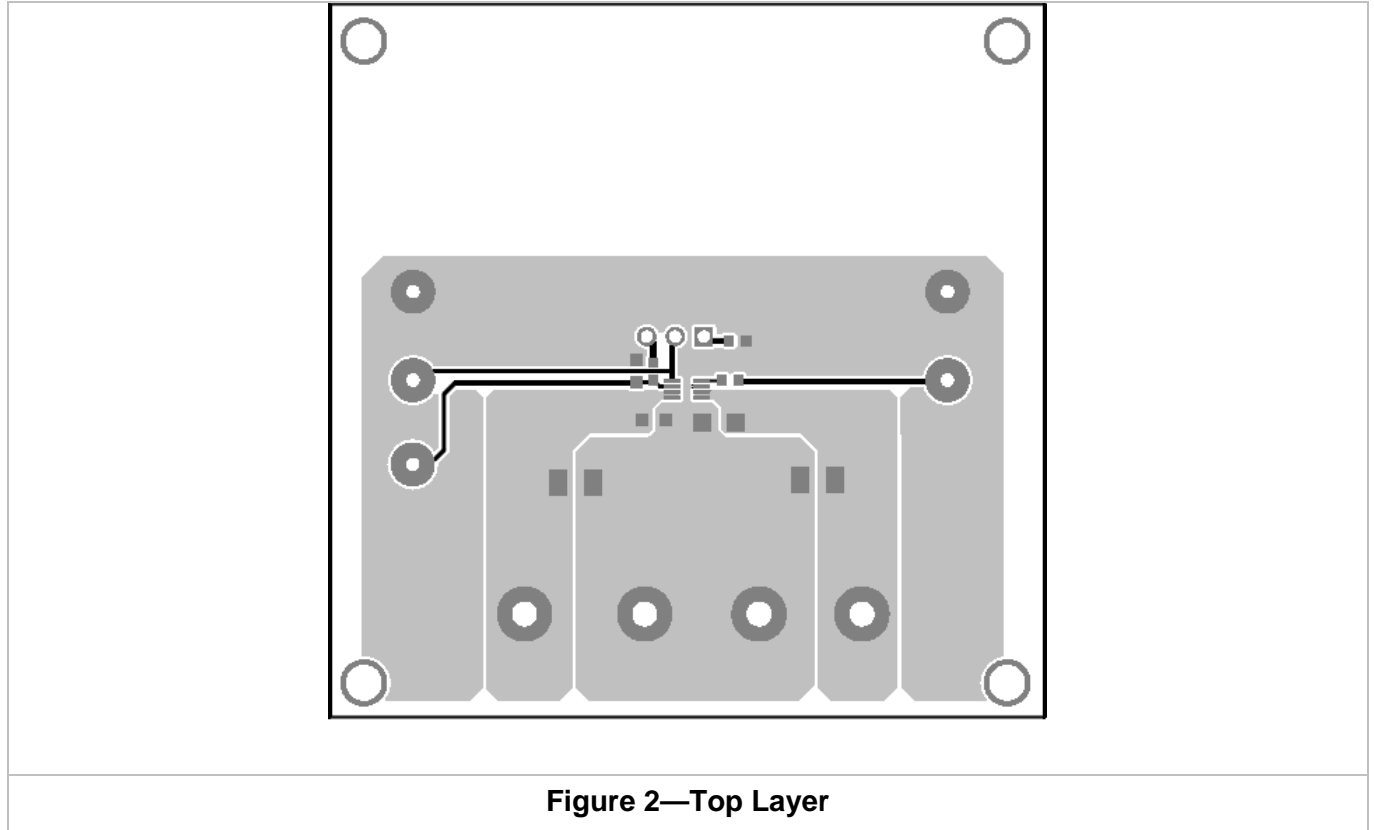

Figure 2—Top Layer

QUICK START GUIDE

The board layout accommodates most commonly used capacitors and resistors.

1. Attach the positive and negative terminators of the load to the OUT and GND pins respectively.
2. Attach the input voltage (max 30V) and input ground to the VIN and GND pins respectively. It will start up when VIN is higher than 2.65V and shut down when VIN is below 2.52V.
3. If the input voltage is higher than 6V, the voltage of OUT pin will drop down to 0V. Input power will be removed from the charger system.
4. The battery over voltage is indicated by VBAT pin, if the Voltage of VBAT is higher than 4.35V, the voltage of OUT pin will drop to 0V. The resistor RVB from BAT to VBAT pin provides a current limit, the recommended value is 200k Ω to 1M Ω .
5. The current limit function of MP2676 is to prevent charging the system with an excessive current, the OCP threshold is preset at 1.6A.
6. Internal integrated P-MOSFET can be controlled by external control signal via GATDRV pin, which can be connected to the charge controller IC to achieve charge function. Connect GATDRV pin to GND will always keep the P-MOSFET fully on. In the contrast, connect the GATDRV pin to CHRIN pin will always keep the P-MOSFET off.

Please refer to the datasheet for the detailed information.

NOTICE: The information in this document is subject to change without notice. Please contact MPS for current specifications. Users should warrant and guarantee that third party Intellectual Property rights are not infringed upon when integrating MPS products into any application. MPS will not assume any legal responsibility for any said applications.