

DESCRIPTION

The EV2565DN-00A is an evaluation board for the MP2565, a high frequency step-down regulator with an integrated power MOSFET.

The MP2565 integrates a 220mΩ MOSFET that provides 2.5A load current over a wide operating input voltage of 4.5V to 50V.

Current mode control provides fast transient response and reliable over current protection. An internal soft-start prevents inrush current at turn-on.

The EV2565DN-00A is a fully assembled and tested PCB. It generates a +3.3V output voltage at load current up to 2.5A from an 8V to 50V input range. Switching frequency is set at 500KHz.

ELECTRICAL SPECIFICATIONS

| Parameter | Symbol | Value | Units |
|----------------|-----------|--------|-------|
| Input Voltage | V_{IN} | 8 – 50 | V |
| Output Voltage | V_{OUT} | 3.3 | V |
| Output Current | I_{OUT} | 2.5 | A |

FEATURES

- 2.5A Output Current
- Programmable Switching Frequency up to 4MHz
- Wide 8V to 50V Operating Input Range
- Adjustable Output from 0.8V

APPLICATIONS

- High Voltage Power Conversion
- Game Machines
- Automotive Systems
- Industrial Power Systems
- Distributed Power Systems
- Printer Systems
- Battery Powered Systems

"MPS" and "The Future of Analog IC Technology" are Registered Trademarks of Monolithic Power Systems, Inc.

EV2565DN-00A EVALUATION BOARD



(L x W x H) 2.5" x 2.5" x 0.4"
(6.35cm x 6.35cm x 1.0cm)

| Board Number | MPS IC Number |
|--------------|---------------|
| EV2565DN-00A | MP2565DN |

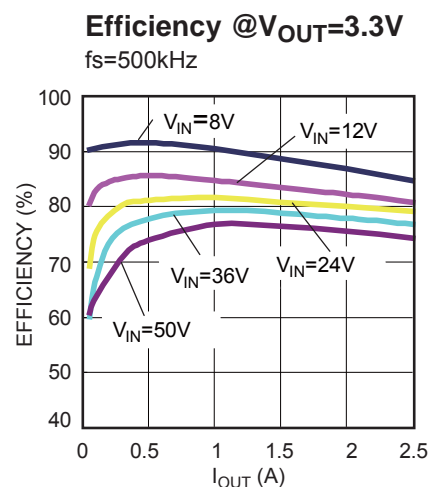

EVALUATION BOARD SCHEMATIC

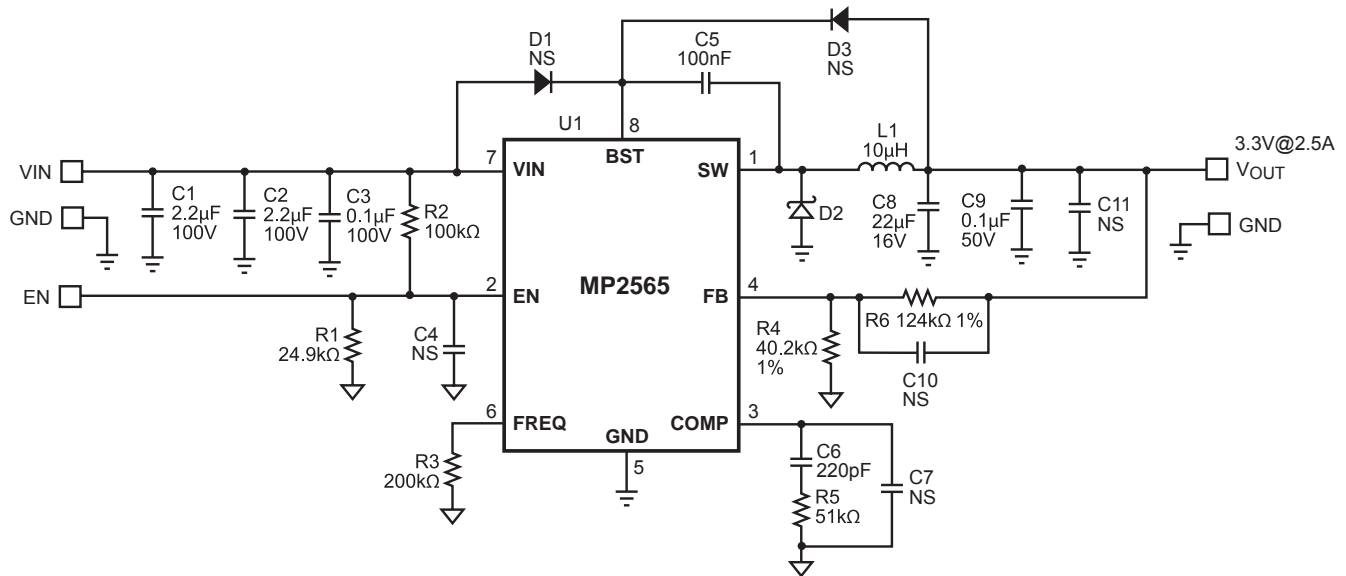

EV2565DN-00A BILL OF MATERIALS

| Qty | Ref | Value | Description | Package | Manufacturer | Part Number |
|-----|------------------|--------|-------------------------|---------|--------------|--------------------|
| 2 | C1, C2 | 2.2µF | Ceramic Cap., 100V, X7R | 1210 | Murata | GRM32ER72A225KA35L |
| 1 | C3 | 0.1µF | Ceramic Cap., 100V, X7R | 0805 | TDK | C2012X7R2A104K |
| 4 | C4, C7, C10, C11 | | Not Stuffed | | | |
| 1 | C5 | 100nF | Ceramic Cap., 50V, X7R | 0603 | TDK | C1608X7R1H104K |
| 1 | C6 | 220pF | Ceramic Cap., 50V, X7R | 0603 | TDK | C1005X7R1H221K |
| 1 | C8 | 22µF | Ceramic Cap., 16V, X7R | 1210 | Murata | GRM32ER71C226ME18L |
| 1 | C9 | 0.1µF | Ceramic Cap., 50V, X7R | 0805 | TDK | C2012X7R1H104K |
| 1 | R1 | 24.9kΩ | Film Res., 1% | 0603 | Yageo | RC0603FR-0724K9L |
| 1 | R2 | 100kΩ | Film Res., 1% | 0603 | Yageo | RC0603FR-07100KL |
| 1 | R3 | 200kΩ | Film Res., 1% | 0603 | Yageo | RC0603FR-07200KL |
| 1 | R4 | 40.2kΩ | Film Res., 1% | 0603 | Yageo | RC0603FR-0740K2L |
| 1 | R5 | 51kΩ | Film Res., 1% | 0603 | Yageo | RC0603FR-0751KL |
| 1 | R6 | 124kΩ | Film Res., 1% | 0603 | Yageo | RC0603FR-07124KL |
| 2 | D1, D3 | | Not Stuffed | | | |
| 1 | D2 | | Diode Schottky, 80V, 3A | SMC | Diodes Inc | B380 |
| 1 | L1 | 10µH | Inductor, 4.3A | SMD | Toko | D104C-#919AS-100M |
| | | | Inductor, 4A | SMD | Cooper | SD8350-100-R |
| | | | Inductor, 4A | SMD | Würth | 744066100 |
| 1 | U1 | | Step-Down Regulator | SO8 | MPS | MP2565DN |

PRINTED CIRCUIT BOARD LAYOUT

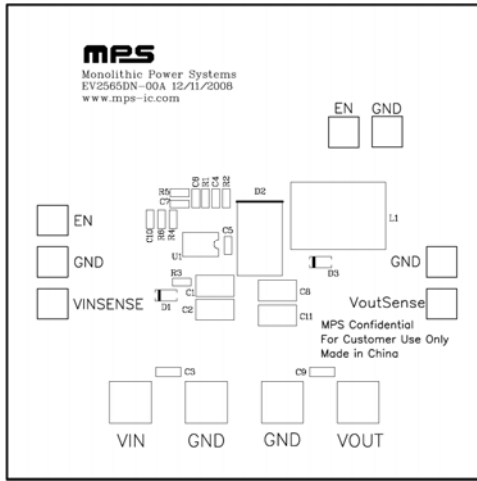

Figure 1—Top Silk Layer

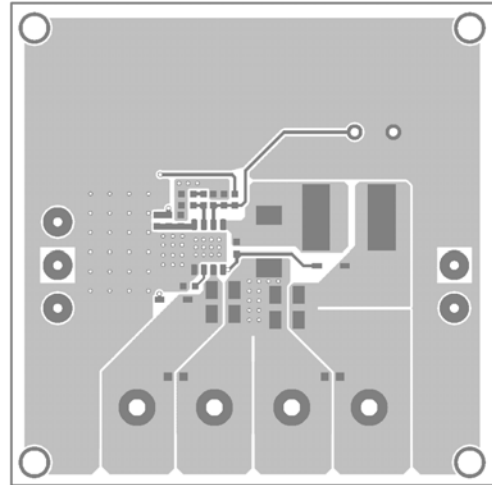

Figure 2—Top Layer

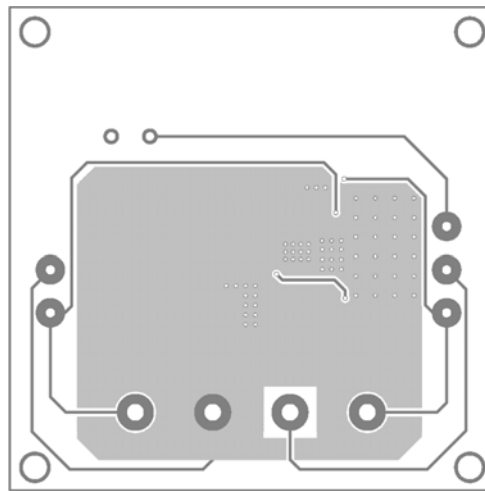

Figure 3—Bottom Layer

QUICK START GUIDE

1. Connect the positive and negative terminals of the load to the VOUT and GND pins, respectively.
2. Preset the power supply output to between 8 and 55V, and then turn it off.
3. Connect the positive and negative terminals of the power supply output to the VIN and GND pins, respectively.
4. Turn the power supply on. The EV2565DN will automatically startup.
5. To use the Enable function, apply a digital input to the EN pin. Drive EN higher than 1.6V to turn on the regulator, drive EN less than 1.2V to turn it off.
6. An input under voltage lockout (UVLO) function is implemented by the addition of a resistor divider R1 and R2. The EN threshold is 1.2V (falling edge), so V_{IN} UVLO threshold is $1.2V \times \left(1 + \frac{R2}{R1}\right)$. It is preset to 6V on this board.
7. Use R4 and R6 to set the output voltage with $V_{FB} = 0.8V$. For $R4 = 40.2k\Omega$, R6 can be determined by: $R6 = 50.25 \times (V_{OUT} - 0.8)(k\Omega)$. Follow the Application Information section in the device datasheet to recalculate the compensation, inductor and output capacitor values when output voltage is changed.

NOTICE: The information in this document is subject to change without notice. Users should warrant and guarantee that third party Intellectual Property rights are not infringed upon when integrating MPS products into any application. MPS will not assume any legal responsibility for any said applications.