



The Future of Analog IC Technology®

# EV24893DJ-00A

## Step-Down White LED Driver Evaluation Board

### DESCRIPTION

The EV24893DJ-00A is an evaluation board for the MP24893DJ, a step-down converter designed in continuous current mode for driving the high brightness LEDs from wide input voltage of 6V to 30V.

The MP24893 employs hysteretic control architecture to regulate a highly accurate LED current, which is measured through an external high-side current-sense resistor. Moreover, this control scheme provides optimal circuit stabilization and a very quick response time without loop compensation. Its low 200mV average feedback voltage reduces power loss and improves the converter efficiency.

The MP24893 implements PWM and analog dimming together through the DIM pin. The MP24893 includes under-voltage lockout, thermal overload protection to prevent damage in the event of an output overload.

### FEATURES

- Internal 36V MOSFET
- Wide 6V-to-30V Input Range
- High Efficiency
- Hysteretic Control
- PWM and Analog Dimming
- 1000:1 PWM Dimming Resolution
- UVLO, Thermal Shutdown

### APPLICATIONS

- Low-Voltage Halogen Replacement
- Low-Voltage General Illumination
- Automotive/Decorative LED Lighting
- Signs/Emergency Lighting
- LED Backlighting

All MPS parts are lead-free and adhere to the RoHS directive. For MPS green status, please visit MPS website under Quality Assurance. "MPS" and "The Future of Analog IC Technology" are Registered Trademarks of Monolithic Power Systems, Inc.

### ELECTRICAL SPECIFICATIONS

Parameter	Symbol	Value	Units
Input Voltage	$V_{IN}$	6–30	V
Output Voltage	$V_{out}$	< $V_{in}$ -3V	
LED Current	$I_{LED}$	500	mA

### EV24893DJ-00A EVALUATION BOARD

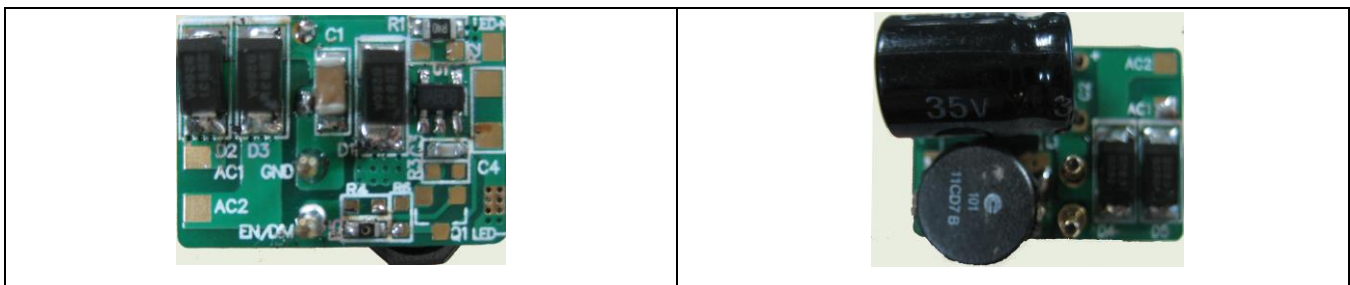

(2x 1.4 x 1) cm xcm x cm

Board Number	MPS IC Number
EV24893DJ-00A	MP24893DJ

## EVALUATION BOARD SCHEMATIC

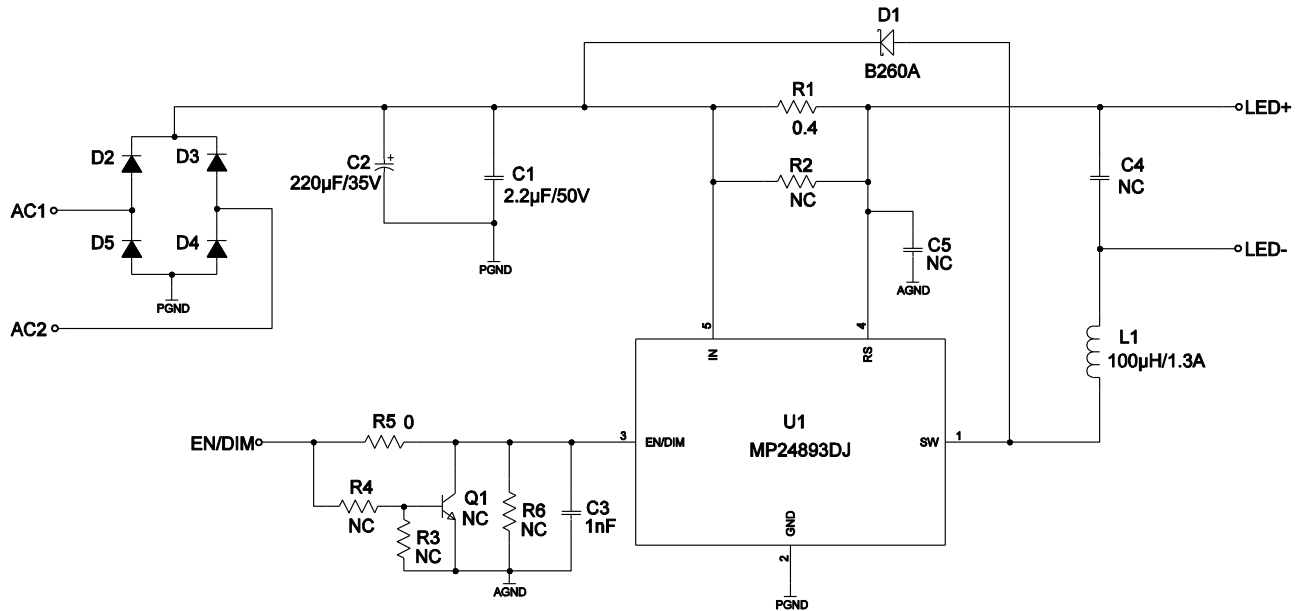

## EV24893DJ-00A BILL OF MATERIALS

Qty	Ref	Value	Description	Package	Manufacturer	Part Number
1	C1	2.2µF	Ceramic Capacitor, 50V, X7R	1206	muRata	GRM31CR71H225KA88L
1	C2	220µF	Electrolytic Capacitor, 35V	DIP	Sanyo	220µF/35V
1	C3	1nF	Ceramic Capacitor, 25V, COG	0603	muRata	GRM1885C1E102JA01D
2	C4, C5	NC				
5	D1-D5	B260A	Schottky Diode	SMA	Diodes Inc.	B260A
1	L1	100µH	Inductor 1.3A	SMD	Cooper	SD8350-101-R
1	R1	0.4Ω	Resistor, 1%	0805	Royalohm	0805F400LT5E
3	R2, R3, R4	NC				
1	R5	0 Ω	Resistor, 5%	0603	Yageo	RC0603JR-070RL
1	R6	NC				
1	Q1	NC				
1	U1	MP24893DJ	MPS WLED Driver	TSOT23-5	MPS	MP24893DJ-R2

PRINTED CIRCUIT BOARD LAYOUT

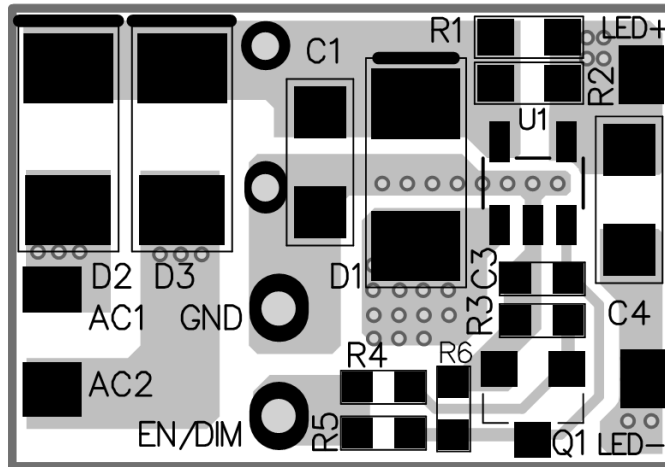

Figure 1—Top Layer

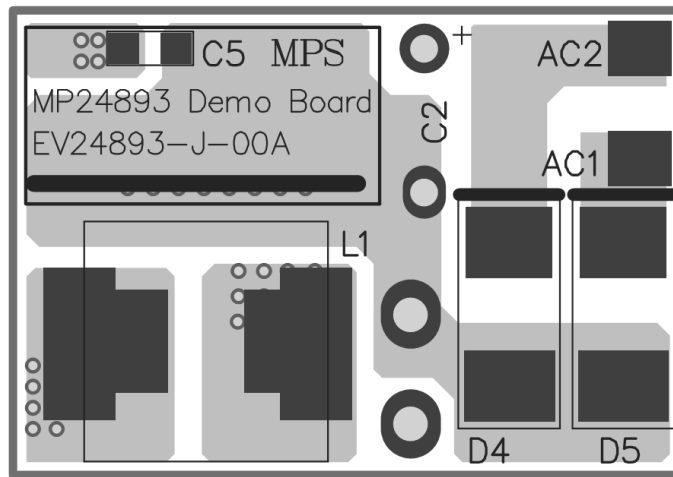

Figure 2—Bottom Layer

## QUICK START GUIDE

1. Connect the positive and negative terminals of the load to the LED+ and LED- pins on the EV board, respectively.
2. Connect the positive and negative terminals of the 24V AC power supply to the AC1 and AC2. If apply a DC power supply, please connect + and – to AC1 and AC2. Turn the power supply on.
3. If PWM dimming is required, provide a 200Hz to 2kHz PWM signal to EN /DIM pin. Remove R5 and put a 1k $\Omega$  resistor on R4. If analog dimming is required, please open R4 and short R5, then provide a 0.3V-to-2.5V DC voltage to the EN/DIM pin.
4. The LED current is adjustable by set current sense resistor R1//R2 as below formula,

$$R1//R2=202mV/I_{LED}$$

**NOTICE:** The information in this document is subject to change without notice. Users should warrant and guarantee that third party Intellectual Property rights are not infringed upon when integrating MPS products into any application. MPS will not assume any legal responsibility for any said applications.