

PRELIMINARY SPECIFICATIONS SUBJECT TO CHANGE

DESCRIPTION

The EV172-S-00A Evaluation Board is designed to demonstrate the capabilities of MP172. The MP172 is a primary-side constant voltage regulator providing accurate constant voltage (CV) regulation without Opto-coupler. It supports Buck, Buck-Boost, Boost and Flyback topologies.

The EV172-S-00A Evaluation Board is designed as Buck application. EV172-S-00A typically drives 5V/120mA load from 85VAC to 265VAC, at 60/50Hz.

The EV172-S-00A has an excellent efficiency and meets IEC61000-4-5 2kV surge immunity and EN55022 conducted EMI requirements. MP172 features various protections, including thermal shutdown (TSD), VCC under-voltage lockout (UVLO), over-load protection (OLP), short-circuit protection (SCP), and open loop protection.

MP172 is available in TSOT23-5 and SOIC8 package.

ELECTRICAL SPECIFICATION

Parameter	Symbol	Value	Units
Input Voltage	V_{IN}	85 to 265	VAC
Output Voltage	V_{OUT}	5	V
Output Current	I_{OUT}	120	mA

FEATURES

- Primary-Side non-isolated Constant Voltage (CV) control
- Integrated 700V/ MOSFET
- <100mW no-load power consumption
- Peak-Current control with peak current compression
- Low VCC operating current
- Limited maximum frequency
- Frequency foldback
- Multiple protections: SCP, OCP, OTP, and VCC UVLO
- Low cost and simple external circuit
- Internally biased VCC

APPLICATIONS

- Home appliance, and consumer electronics
- Home automation
- Standby power

All MPS parts are lead-free, halogen free, and adhere to the RoHS directive. For MPS green status, please visit MPS website under Quality Assurance.

"MPS" and "The Future of Analog IC Technology" are Registered Trademarks of Monolithic Power Systems, Inc.



High Voltage

Warning: Although this board is designed to satisfy safety requirements, the engineering prototype has not been agency approved. Therefore, all testing should be performed using an isolation transformer to provide the AC input to the prototype board.

EV172-S-00A EVALUATION BOARD

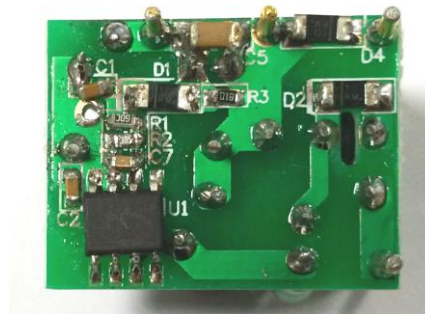

(L x W x H) 17mm x 22mm x 17mm	
Board Number	MPS IC Number
EV172-S-00A	MP172GS

EVALUATION BOARD SCHEMATIC

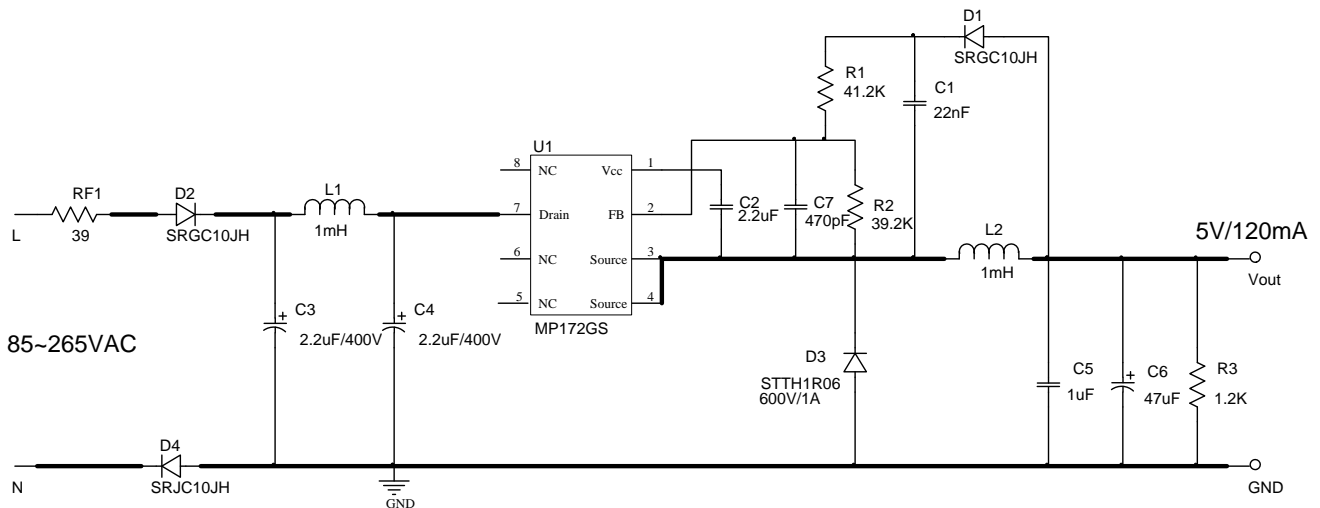

Figure 1—Schematic

BILL OF MATERIALS

Qty	Ref	Value	Description	Package	Manufacture	Manufacture_PN
1	C1	22nF	Ceramic Capacitor;16V;X7R	0603	muRata	GRM188R71C223KA01D
1	C2	2.2μF	Ceramic Capacitor;10V;X7R	0603	muRata	GRM188R71A225KE15D
2	C3, C4	2.2μF	Electrolytic Capacitor;400V;	DIP	Rubycon	400LLE2R2MEFC
1	C5	1μF	Ceramic Capacitor;25V;X7R	1206	muRata	GRM31MR71E105KA01
1	C6	47μF	Electrolytic Capacitor;25V	DIP	Jianghai	CD28L-25V47
1	C7	470pF	Ceramic Capacitor;50V;X7R	0603	TDK	C1608X7R1H471K
3	D1, D2, D4	SRGC10MH	Diode;1000V;1A	1206	ZOWIE	SRGC10MH
1	D3	STTH1R06	Diode;600V;1A	DO-41	ST	STTH1R06
1	L1	1mH	Inductor;17.4Ω;100mA	DIP	Any	Any
1	L2	1mH	Inductor;6Ω;250mA	DIP	Würth	7447462102
1	R1	41.2k	Film Resistor;1%	0603	Yageo	RC0603FR-0741K2L
1	R2	39.2k	Film Resistor;1%	0603	Yageo	RC0603FR-0739K2L
1	R3	1.2k	Film Resistor;1%	0603	Yageo	RC0603FR-071K2L
1	RF1	39	Fuse Resistor;5%;1W	DIP	Yageo	FKN1WSJT-52-39R
1	U1	MP172	Buck regulator	SOIC8	MPS	MP172GS

PCB LAYOUT (SINGLE-SIDED)

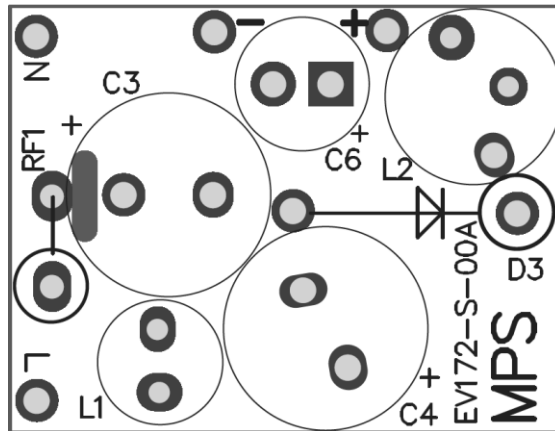

Figure 2—Top Layer

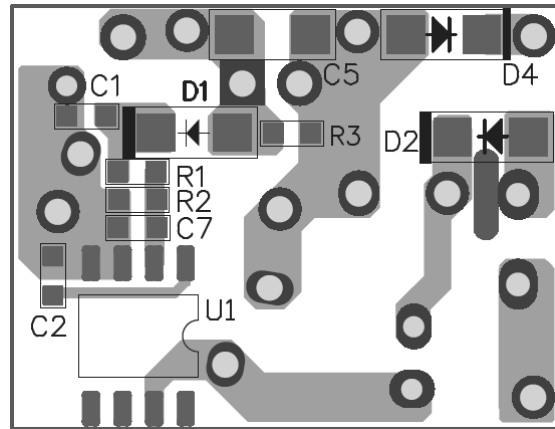

Figure 3—Bottom Layer

CIRCUIT DESCRIPTION

The EV172-S-00A is configured in a buck topology to demonstrate the performance of MP172. MP172 is a primary side controller which provides accurate constant voltage. It simplifies the schematic and minimizes the BOM cost.

FR1 is used to protect circuit from component failure or some excessive short events; also it can restrain the inrush current.

C3, L1, C4 compose CLC filter to meet the conducted EMI standard EN55022. C3 and C4 are also used for energy storage and protecting against line surge.

With FR1, C3 and C4 used, EV172-S-00A meets calss3 (2kV) IEC61000-4-5 surge immunity standard.

C1 is the sample-hold capacitor used for reflecting output voltage. R1 and R2 are resistor divider for detecting output voltage by sampling voltage on C1.

D3 is the freewheeling diode. For universal voltage applications, use a diode with a 600V reverse block voltage. Fast recovery diode or ultra fast diode is recommended for better efficiency and reliable operation.

C6 is the output capacitors for 5V output. R3 is dummy load to lower the output voltage under no load condition.

QUICK START GUIDE

1. Preset power supply to $85\text{VAC} \leq V_{\text{IN}} \leq 265\text{VAC}$.
2. Turn power supply off.
3. Connect the Line and Neutral terminals of the power supply output to L and N port.
4. Connect load positive and negative terminals to corresponding + and - outputs.
5. Turn power supply on after making connections.

NOTICE: The information in this document is subject to change without notice. Please contact MPS for current specifications. Users should warrant and guarantee that third party Intellectual Property rights are not infringed upon when integrating MPS products into any application. MPS will not assume any legal responsibility for any said applications.