



Application Note

# Using MagAlpha™ Devices to Replace Optical Encoders

## Introduction

The standard way to measure the angular position or speed of a rotating shaft is to use an optical encoder. Optical encoders typically use LEDs and photodetectors, in conjunction with a wheel or disc that periodically interrupts or reflects the beam of light between the LED and photodetector.

Optical encoders suffer from several problems:

- They are expensive, especially at high resolutions
- They are subject to problems due to contamination (dirt) obstructing the optical path, leading to failure
- They require difficult manual adjustment of the “zero” position
- They can be quite large and bulky

As an alternative to optical encoders, devices have been developed to measure the angle and speed of a shaft using magnetic technology and Hall-effect-based silicon devices. In many cases, using an IC magnetic sensor like the Sensima MagAlpha™ device is a better choice.

## The MagAlpha™ Device

The Sensima MagAlpha™ device is an IC that can sense directly the angle of an external magnetic field. These devices use proprietary techniques to measure the angle of the field with high accuracy even at high rotation speed.

Commonly, magnetic angle sensors are used with a 2-pole magnet oriented above the surface of the IC (shown on the left in the image below). In addition, the MagAlpha™ devices include side-shaft compensation, which allows them to measure accurately the angle of a magnet placed to the side of the device (shown on the right in the image below).

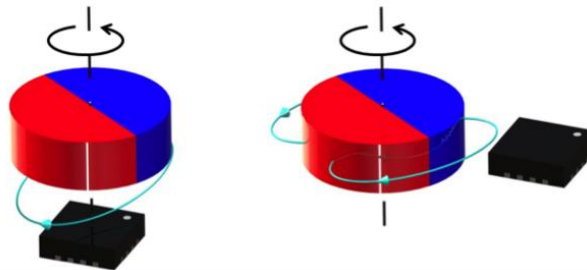

For more details on MagAlpha™ device operation, please refer to the MAxxx datasheets available at [www.monolithicpower.com](http://www.monolithicpower.com).

## Encoder Mechanical Configurations

Encoders come in many sizes and shapes, but they can be divided into two basic configurations:

*Through-shaft or hollow encoders* – These encoders are mounted to a rotating shaft that passes all the way through the encoder. Usually the code wheel mounts directly to the shaft, and the body of the encoder is mounted to a fixed structure (often a motor).



To use a MagAlpha™ device to replace a through-shaft encoder, the MagAlpha™ part is mounted on a PC board to the side of the shaft, and a ring magnet is fitted to the shaft. Since the “zero” position can be set electronically, the magnet can be mounted with an arbitrary rotation with regard to the mechanical position.

A magnet with more than one pair of poles can be used. In this case the MagAlpha device will indicate multiple rotations for each mechanical revolution.

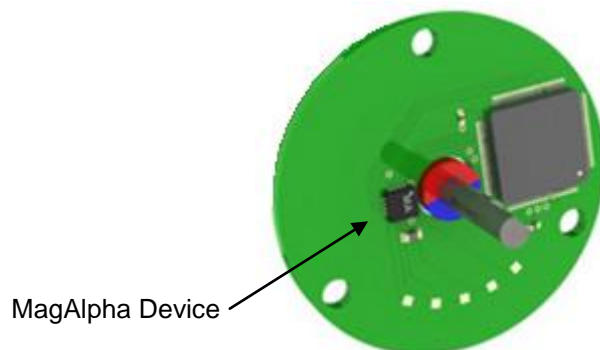

*End-shaft encoders* – Often looking like a motor or potentiometer, end-shaft or solid encoders are self-contained and have a shaft protruding from one end. The shaft is coupled to the rotating machinery using a shaft coupler, gears, or a belt.

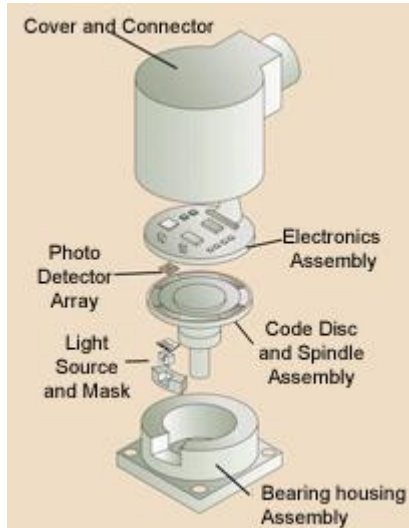

Replacing a solid-shaft encoder with a MagAlpha™ device is straightforward. A small disc magnet is affixed to the end of the shaft in place of the optical code wheel, and the MagAlpha™ device is positioned on a PC board at the end of the shaft.

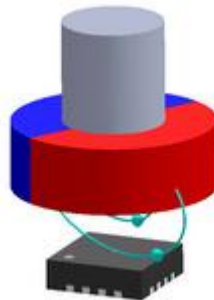

## Absolute and Incremental Encoders

There are two basic types of optical encoders:

*Incremental Encoder* – These encoders typically provide two digital outputs in quadrature (“Phase A” and “Phase B”). With these two signals, the relative position, rotation direction, and speed of the shaft can be determined. Often, a third channel (called the “index” signal or “Phase Z”) is present, which provides an indication of one particular shaft orientation. When there is no motion, no information is output – therefore, incremental encoders can only measure movement, not static position. While moving, the system can track position by counting pulses on the A and B outputs relative to the index channel.

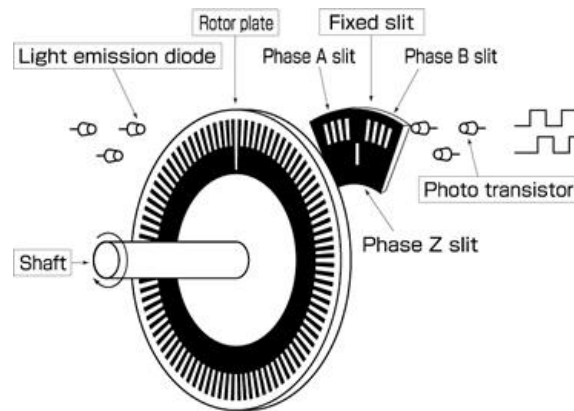

Incremental Encoder Simplified Structure

*Absolute encoder* – Absolute encoders provide an indication of shaft position regardless of movement of the shaft. Typically they use multiple optical devices, one per bit of resolution. Absolute optical encoders become very expensive at high resolutions.

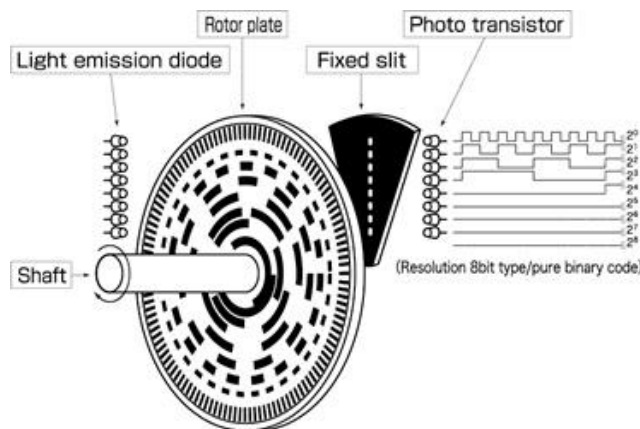

Absolute Encoder Simplified Structure

The MagAlpha™ device can be used in both incremental and absolute applications.

### Electrical Interfacing

Incremental encoders typically have an interface that uses three signals, plus a power supply and ground. The MagAlpha™ devices generate the exact same signals: Quadrature outputs (called “A” and “B”) and an index signal (“Z”).

The MagAlpha™ devices require a power supply of 3.3V, and the output signals are push-pull CMOS outputs. In many cases, these can be directly interfaced with the host system. If an exact duplication of an optical encoder interface is desired (which typically has open-collector outputs or differential TTL outputs), a few components need to be added, as shown in the diagrams below:

#### Differential Interface

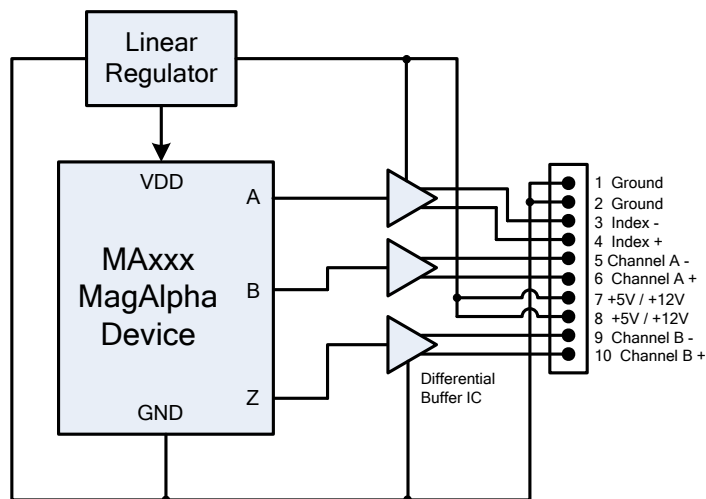

#### Single-Ended Open-Drain Interface

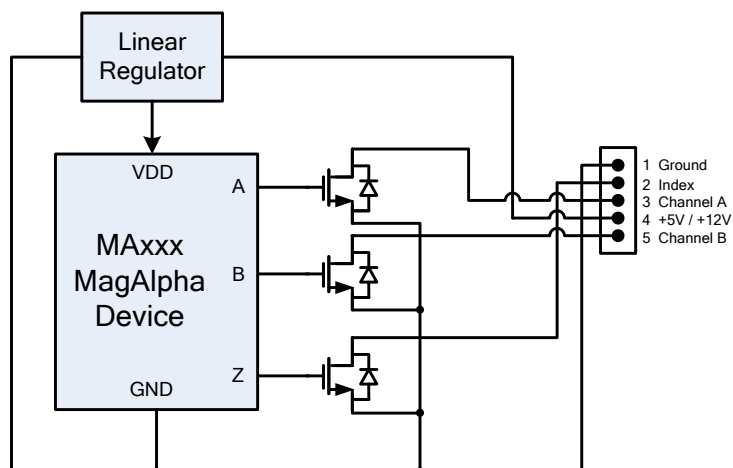

Absolute encoders have different interface requirements, and there is not as much standardization as with incremental encoders. Often, synchronous or asynchronous serial interfaces are used, or sometimes parallel binary interfaces.

Absolute position information is read from the MagAlpha™ device via a serial (SPI) interface. Typically this is connected to a microcontroller.

In systems that already employ a processor, it is possible to directly connect the SPI interface of the MagAlpha™ part to the processor. In other cases, a local microcontroller (located adjacent to the device) can be used to create whatever interface that is required (RS-422 serial, CAN, etc.)

### Absolute Encoder

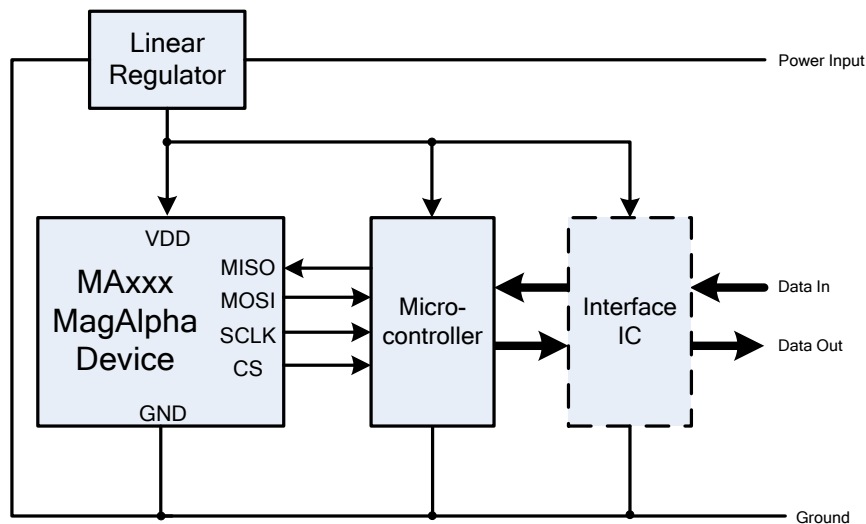

## **Zero Position**

One of the unique advantages of using a MagAlpha™-based encoder over an optical encoder is that the zero position is easily set without requiring precise mechanical adjustment.

The MagAlpha™ devices have registers, accessible through the SPI interface, which sets the zero (home) position. The contents of these registers can then be programmed into local nonvolatile memory. This can be done as an automated step in the manufacturing process.

To program the zero position, the mechanics (shaft) are placed into a known home position. Then, the absolute angle is read from the device. Since initially the zero position is set to the intrinsic physical zero, the value read is an angle that corresponds to the desired new zero setting.

This value is now programmed into the “zero” registers within the device, so it becomes the new zero position.

To store this into nonvolatile memory, voltage is supplied to the FLASH pin, and a register write is performed that programs that value into nonvolatile memory. The entire process can be completed in seconds.

## **Conclusion**

Sensima MagAlpha™ devices can be used as a cost-competitive alternative to optical shaft encoders. Their resolution and insensitivity to dust and dirt are significant advantages, especially in industrial applications.